

Setting up a Petrochemical Industry for the Future: A Technology Journey

Dr Richard Charlesworth

Executive Director, Industry Processes & Cost Analytics

APIC 2025, Bangkok, Thailand

S&P Global

Commodity Insights

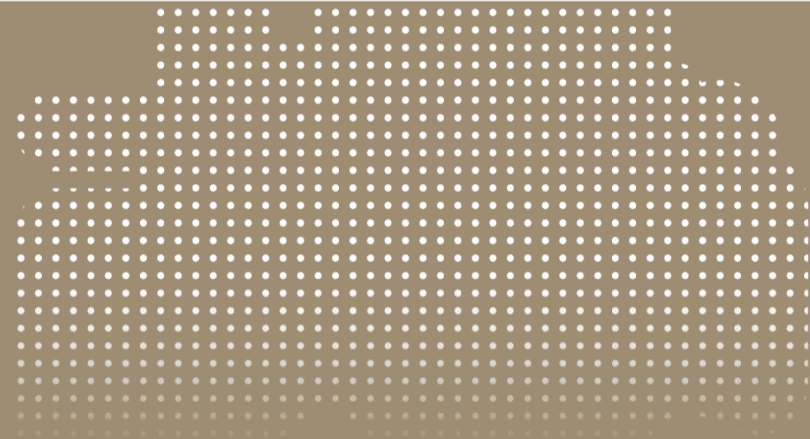

Agenda

A future certainty

A smorgasbord of options

The devil is in the detail

Another future certainty

Key takeaways

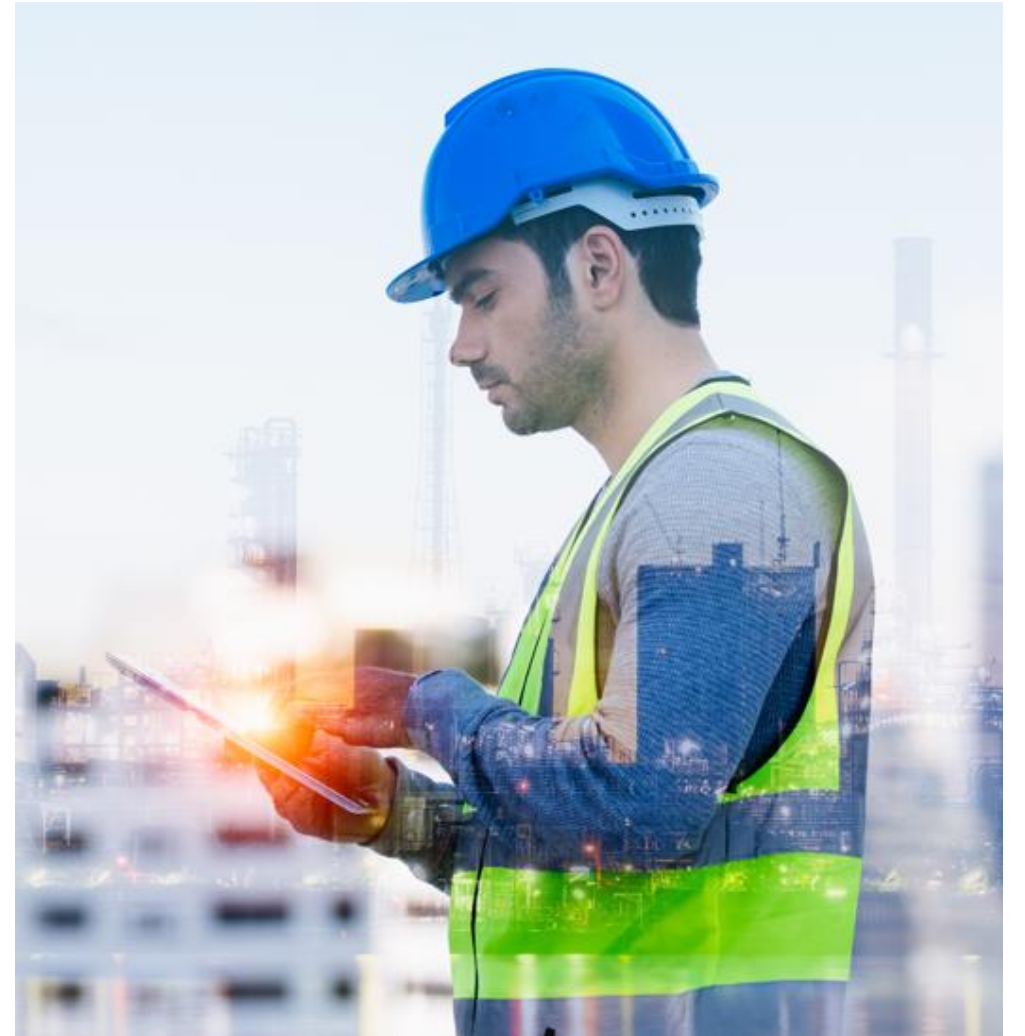

Agenda

A future certainty

A smorgasbord of options

The devil is in the detail

Another future certainty

Key takeaways



Global emissions have risen with GDP despite climate policies and CET advances

Global energy-related CO₂ emissions vs. global GDP

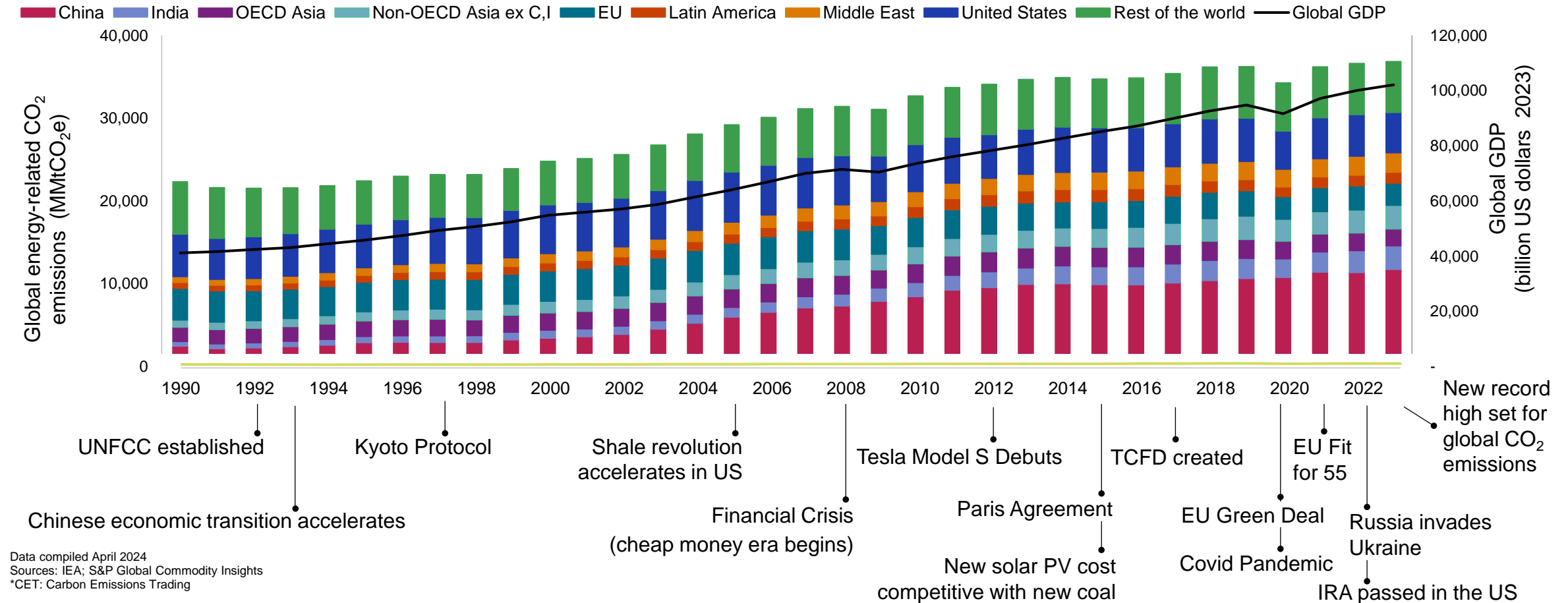

Data compiled April 2024
Sources: IEA; S&P Global Commodity Insights
*CET: Carbon Emissions Trading

One certainty is that the future energy and petrochemical industry will be a decarbonized one, albeit the pace is slowing

Company reported GHG emissions 2023 vs. net-zero targets

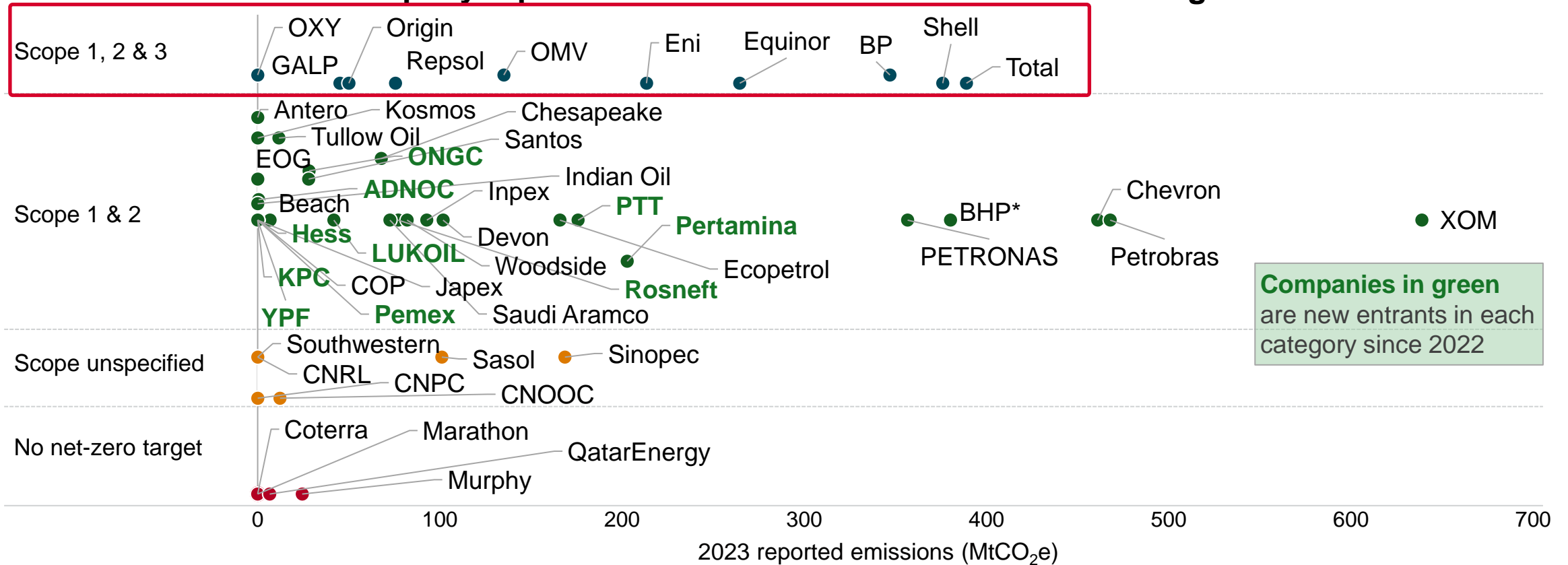

Companies in green are new entrants in each category since 2022

Note: 2023 GHG emissions are reported and may cover Scope 1, Scope 1 and 2, or Scope 1, 2, and 3, depending on company
 *BHP has a Scope 3 target, but for shipping only
 Source: S&P Global Commodity Insights

Agenda

A future certainty

A smorgasbord of options

The devil is in the detail

Another future certainty

Key takeaways



Technology developments are driven largely by decarbonization targets. There are multiple opportunities to manage emissions along the value chain

Crude oil/
natural gas

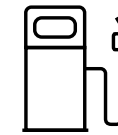
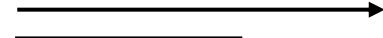
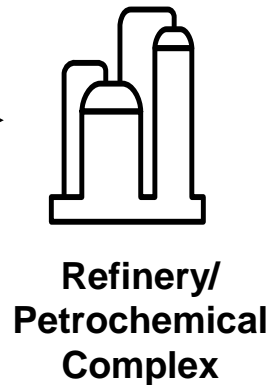

Transportation fuels



Petrochemicals

Technology developments are driven largely by decarbonization targets. There are multiple opportunities to manage emissions along the value chain

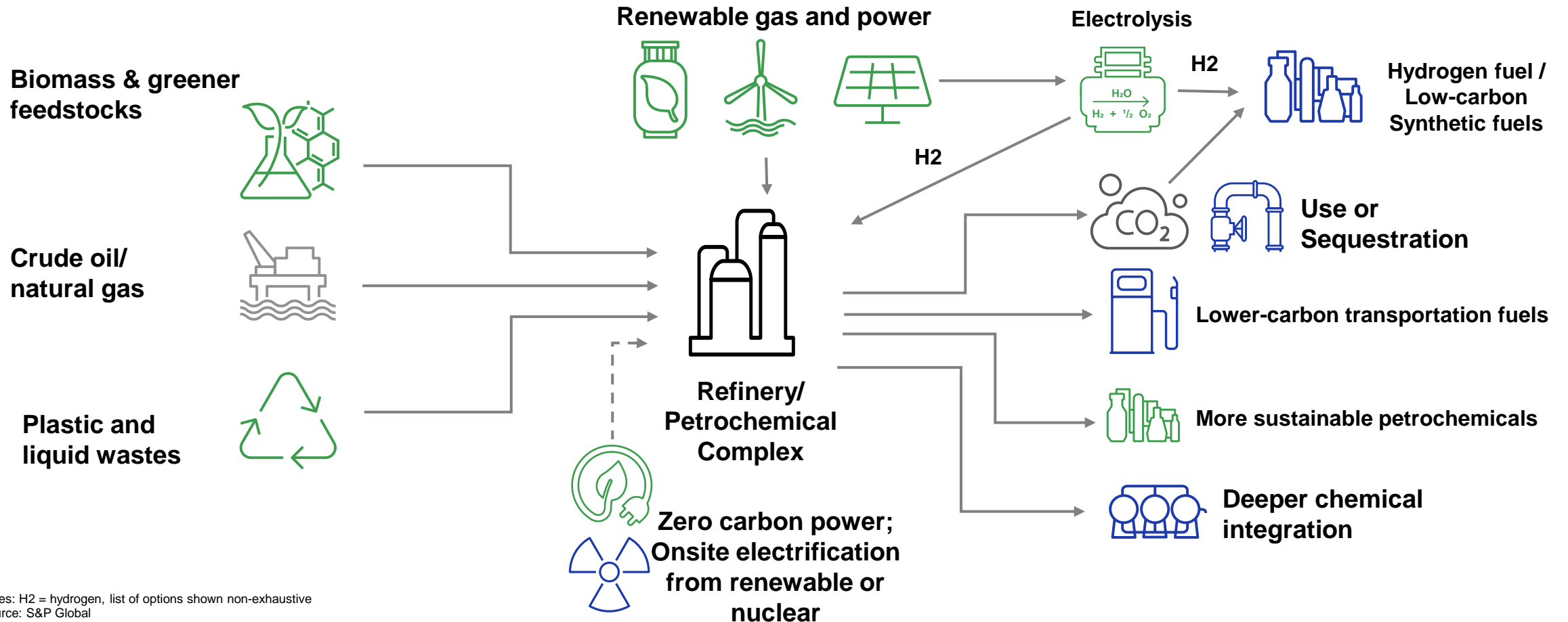

Notes: H₂ = hydrogen, list of options shown non-exhaustive
Source: S&P Global

Agenda

A future certainty

A smorgasbord of options

The devil is in the detail

Another future certainty

Key takeaways



Technology developments are driven largely by decarbonization targets. There are multiple opportunities to manage emissions along the value chain

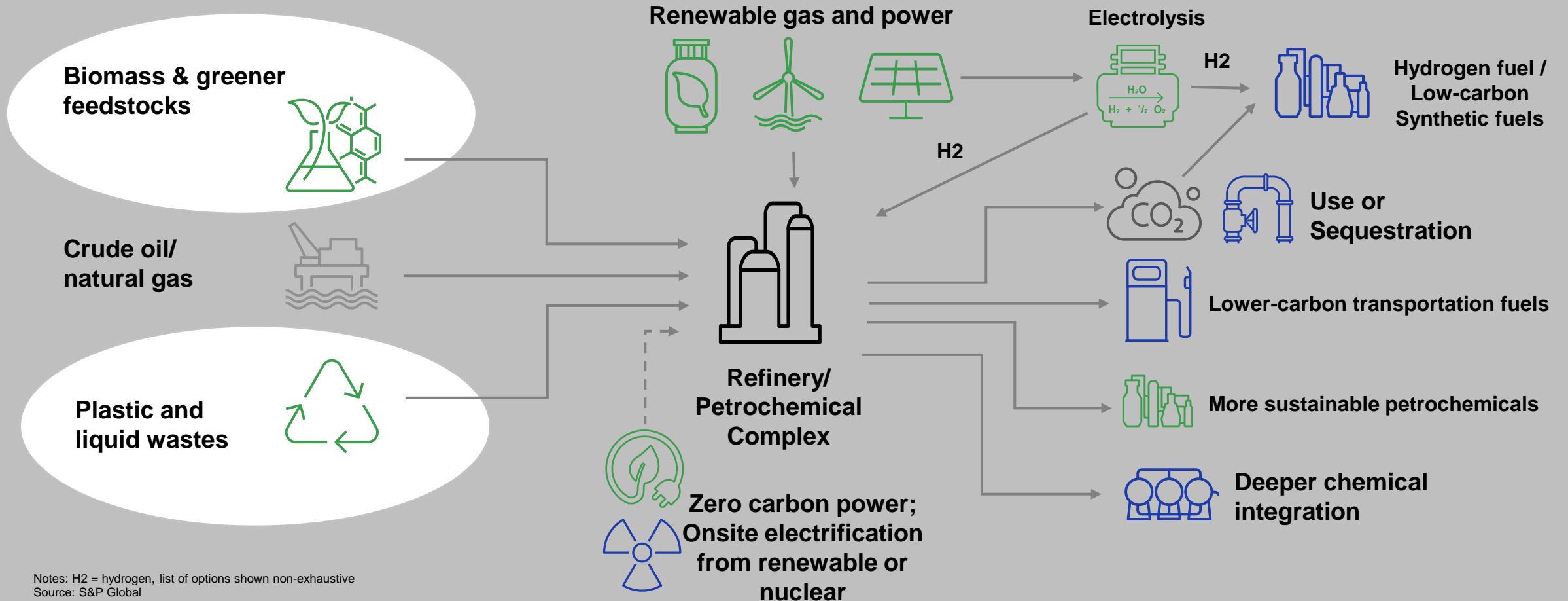

Notes: H₂ = hydrogen, list of options shown non-exhaustive
Source: S&P Global

SAF production pathways

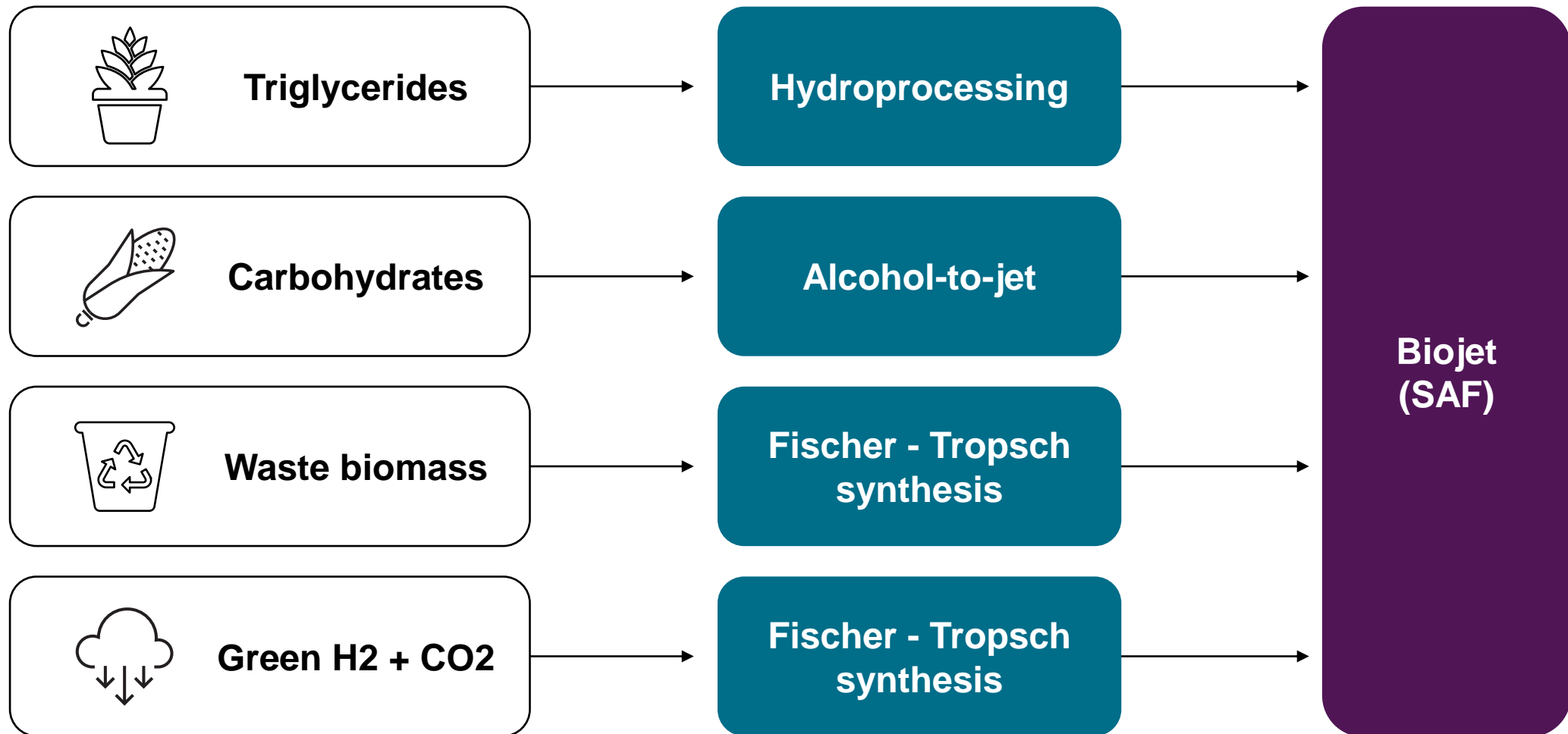

SAF provides price premium

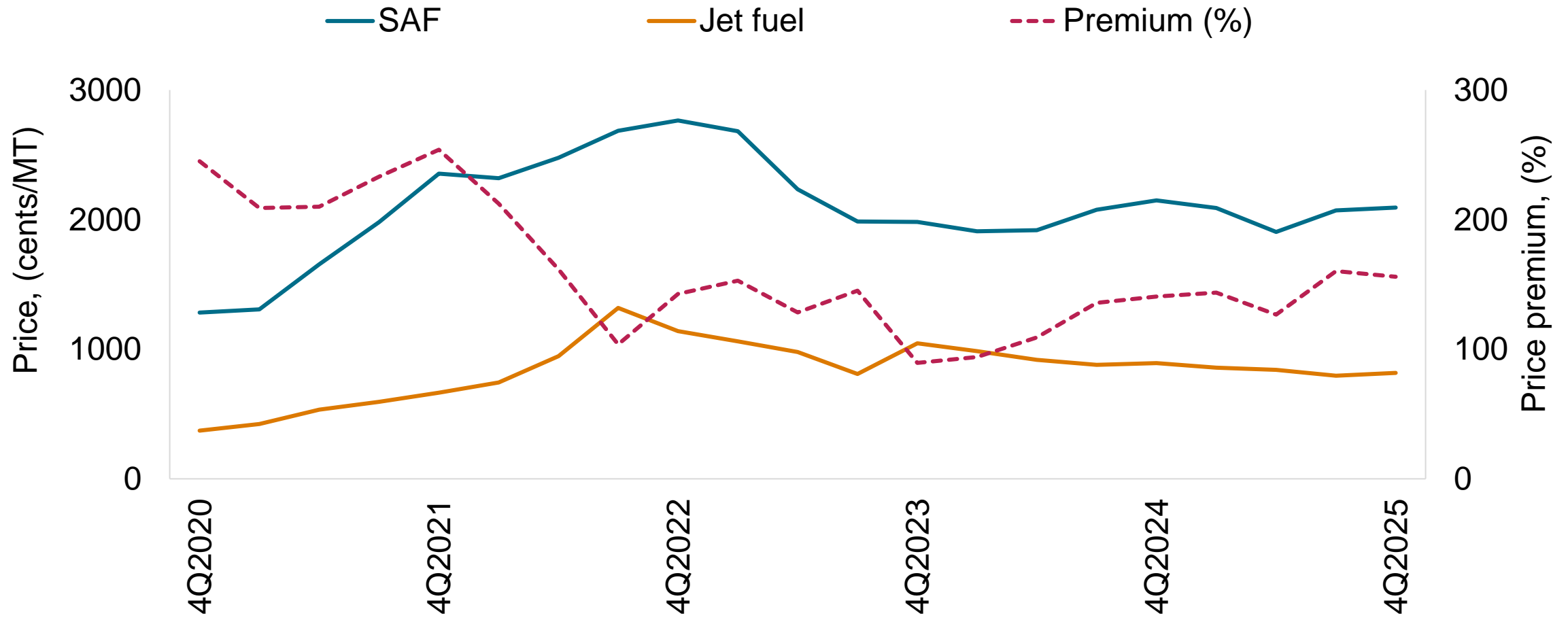

Bio-feedstocks can replicate a variety of petrochemical-based chemicals

Value Chain	Bio-Based Derivatives	Producers
C2	<ul style="list-style-type: none"> Ethylene/Green Polyethylene Ethylene Oxide/ PEGs Ethylene Glycol 	<ul style="list-style-type: none"> Braskem, SABIC, Sustainea, Lyondell-Basell Croda Chemical, Jilin Bohai Biochem India Glycols, Anhui Guozhen
C3	<ul style="list-style-type: none"> Propylene Glycol 1,3-Propanediol Green Polypropylene 	<ul style="list-style-type: none"> Archer Daniels Midland, Oleon DuPont/Tate & Lyle, Zhanjiagang Glory Borealis, SABIC, Lyondell-Basell
C4	<ul style="list-style-type: none"> 1,4-Butanediol Succinic Acid 2,3-Butylene Glycol 	<ul style="list-style-type: none"> Genomatica, Matrica Roquette, Succinium, LCY BioSciences Genomatica, Zhanjiagang Glory
C5	<ul style="list-style-type: none"> Xylose/Xylitol Furfural Levullinic Acid 	<ul style="list-style-type: none"> Danisco, Roquette, COFCO BioChem Aurus Specialties, Hongye BioChemical GBF BioChemicals
C6+	<ul style="list-style-type: none"> Adipic Acid 2,5-Furandicarboxylic Acid Sorbitol, Isosorbide 	<ul style="list-style-type: none"> Genomatica Avantium, DuPont/Archer Daniels Midland Roquette, Samyang



However, the production cost of bio-based PET and bio-based PP versus fossil-based polymers is around double (Q4 2024)

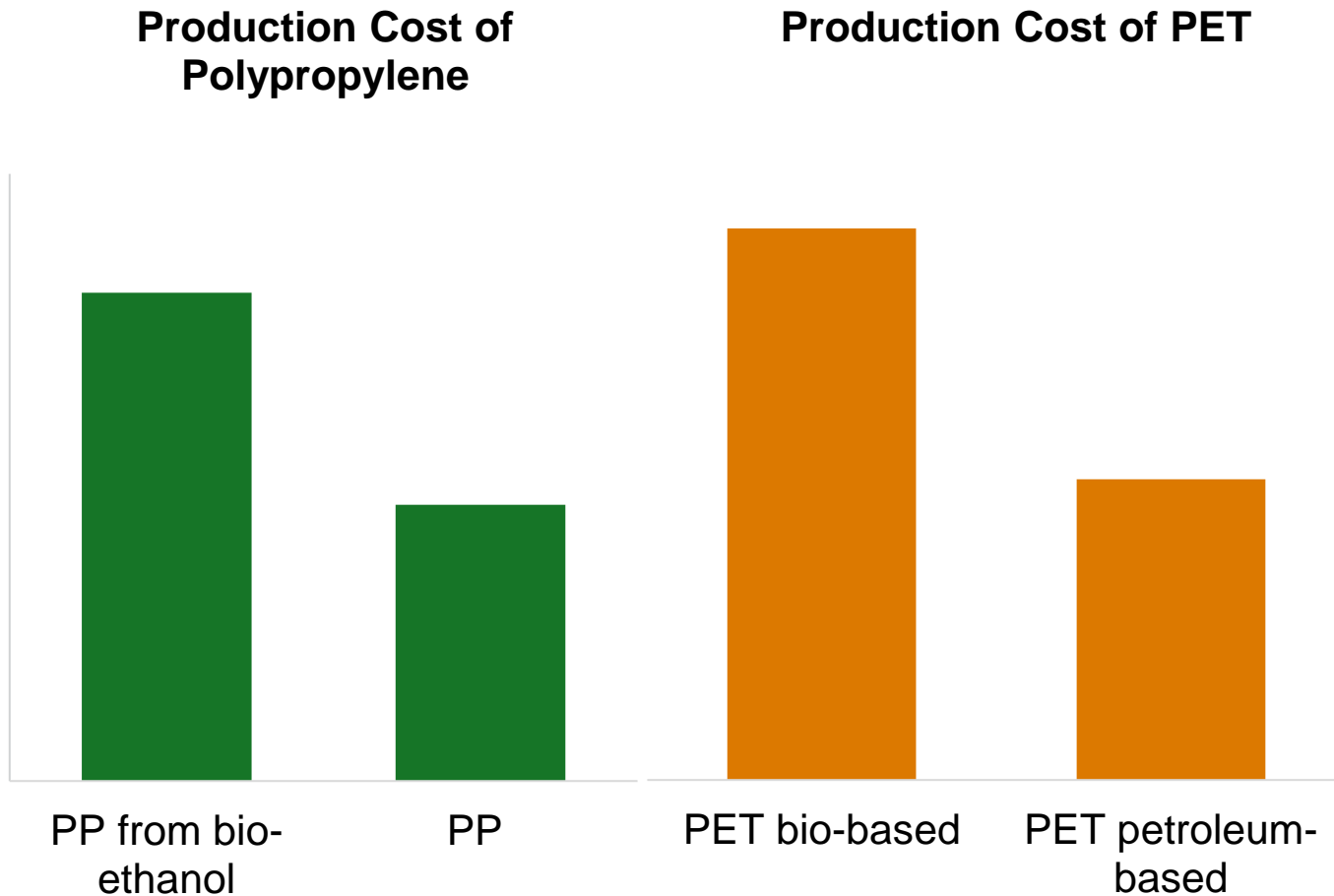

Source: S&P Global Markit Process Economics Program (PEP) Reports

Bio-based polymers command a premium to enter the market

Recycled PET follows a similar trend due to added costs of collection, sorting, upgrading, etc.

China's capacity expansions will further challenge bio-based PET's market position

Beyond mechanical and existing chemical recycling technology, the next generation is catalytic pyrolysis

Feedstock requirement: mainly PE/PP, clean, homogeneous

Products: Mainly oil, smaller amount of gas

Company: LyondellBasell 50 kta plant 2025/2026

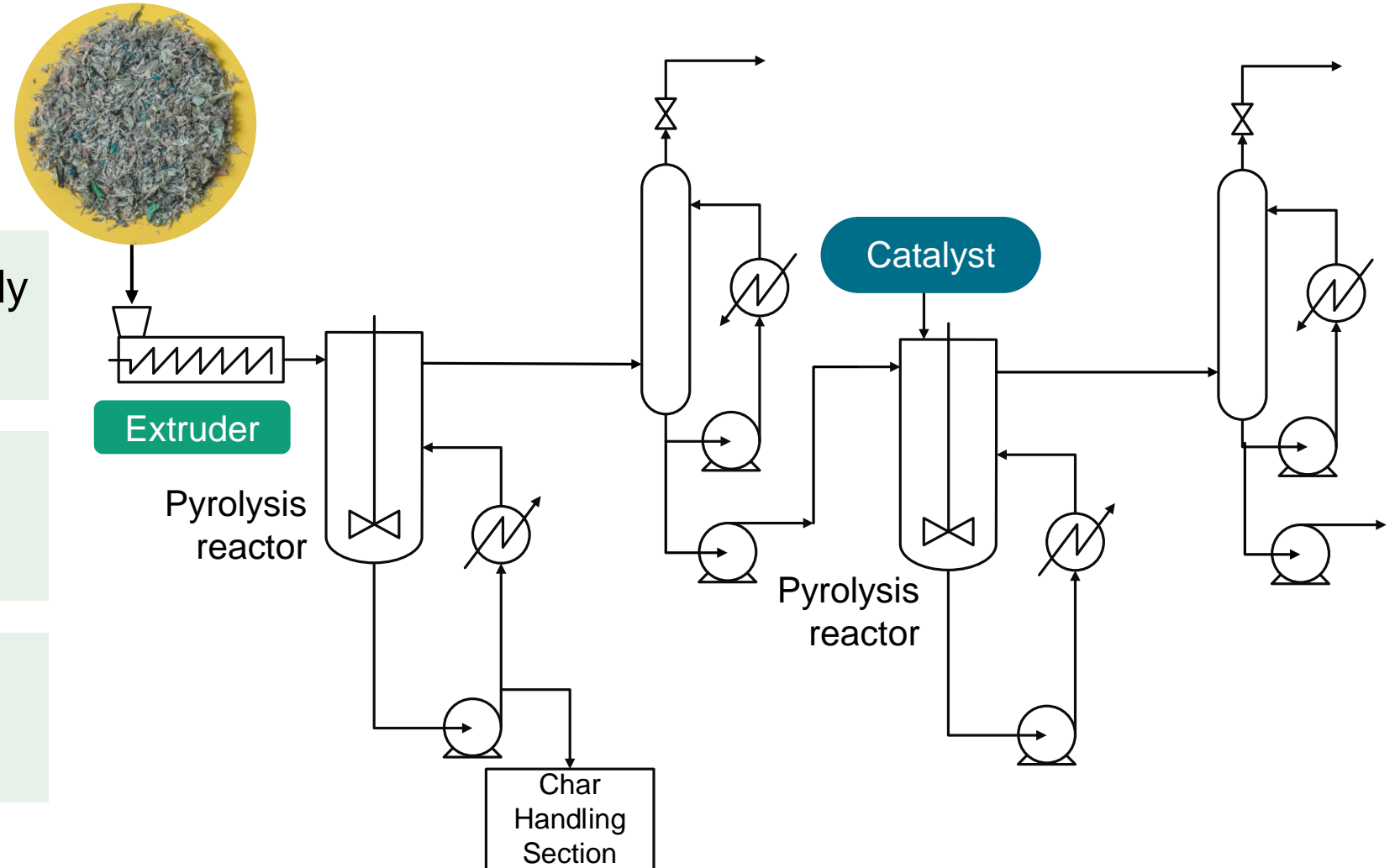

Source: US20240059974A1

However, the production cost of recycling and upgrading is substantial (\$/ton)

Basis: USGC, 3Q 2024, 100kta plastic waste (5 cent/lb mixed polyolefin bale, 10 cent/lb HDPE bale grade C)

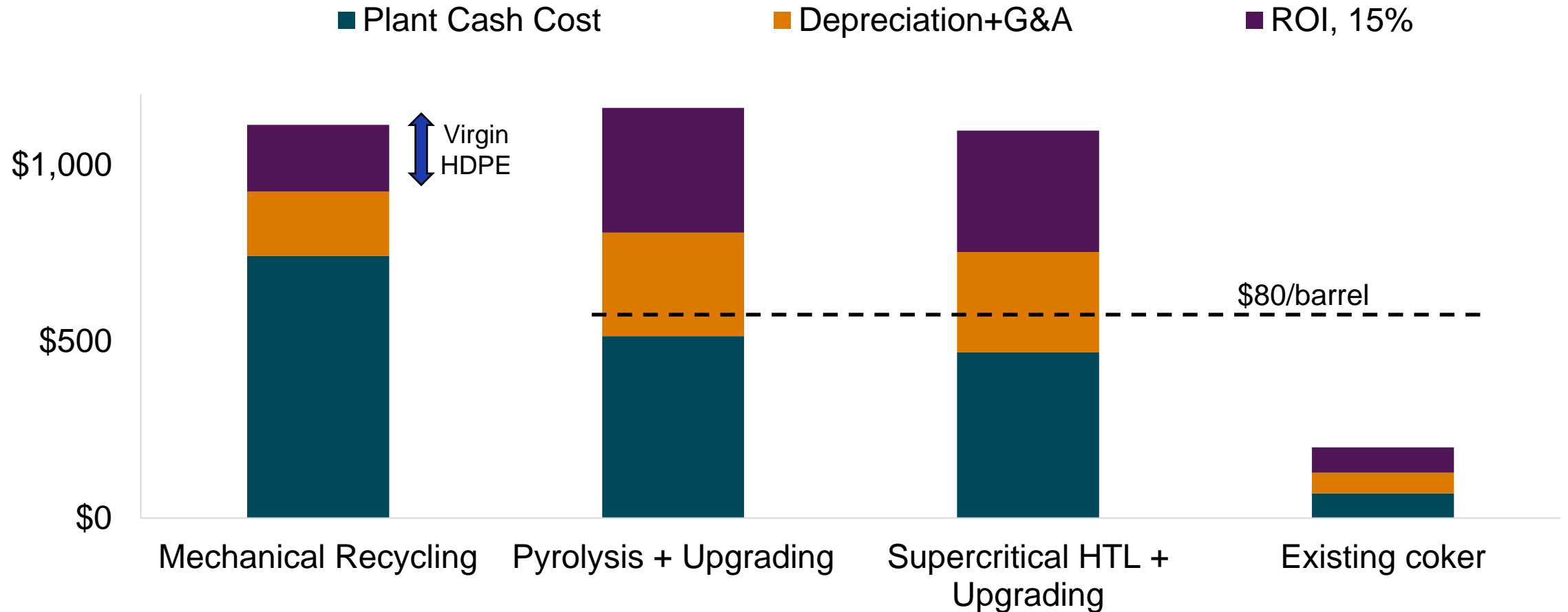

Source: S&P Global Markit Process Economics Program (PEP) Reports

Technology developments are driven largely by decarbonization targets. There are multiple opportunities to manage emissions along the value chain

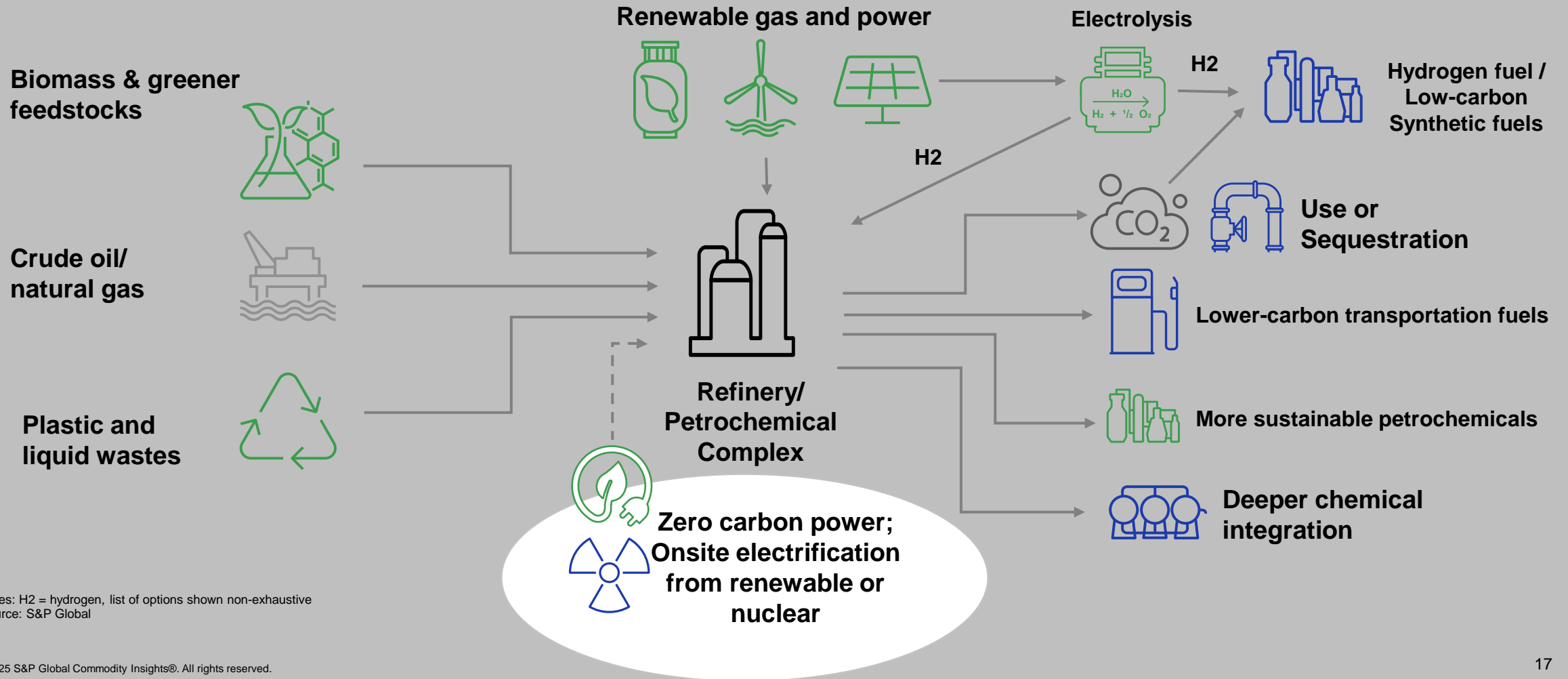

Low carbon power - NET Power has developed a process using supercritical CO₂ as operating medium for natural gas oxycombustion

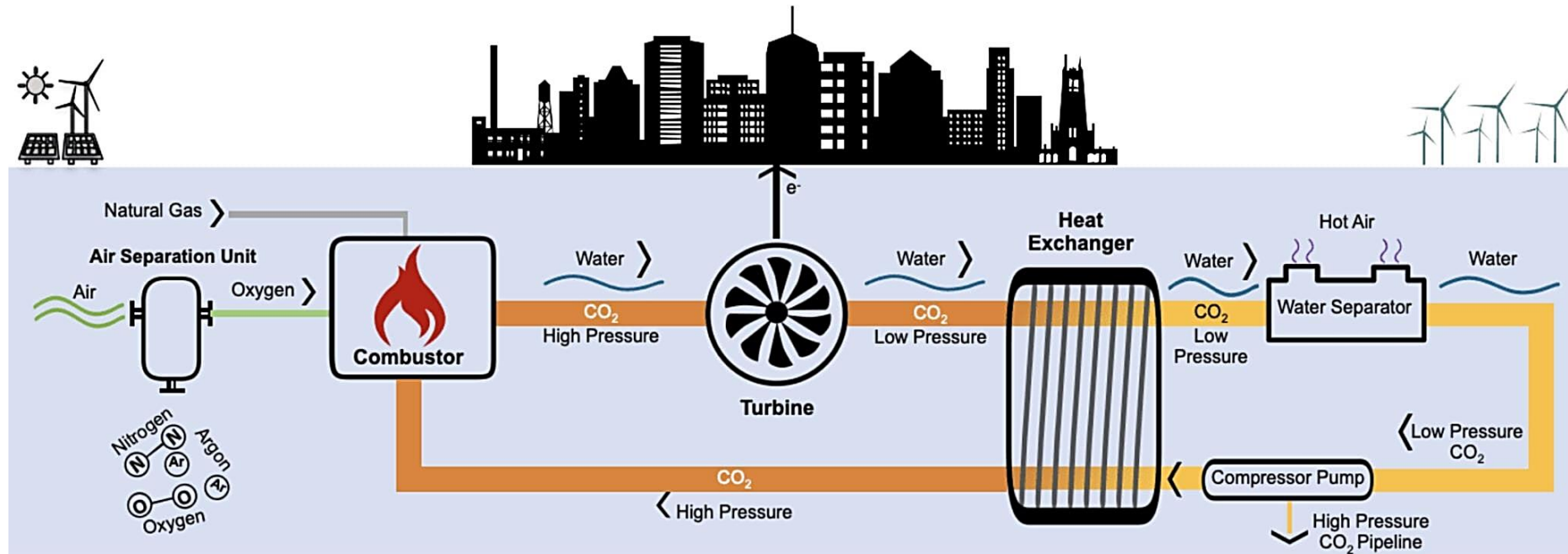

325 MW Plant	Natural Gas Combined Cycle	NET Power
Relative Capital Intensity, per KW	1.00	1.60
LCOE with CO ₂ Credit, \$/MWh	--	~\$10-15 per MWh lower

Source: Powermag.com & : PEP Review 2021-02, Electric Power via the Allam Cycle

NuScale Power Module™ (NPM) is the first small modular reactor (SMR) to receive design approval from the U.S. Nuclear Regulatory Commission

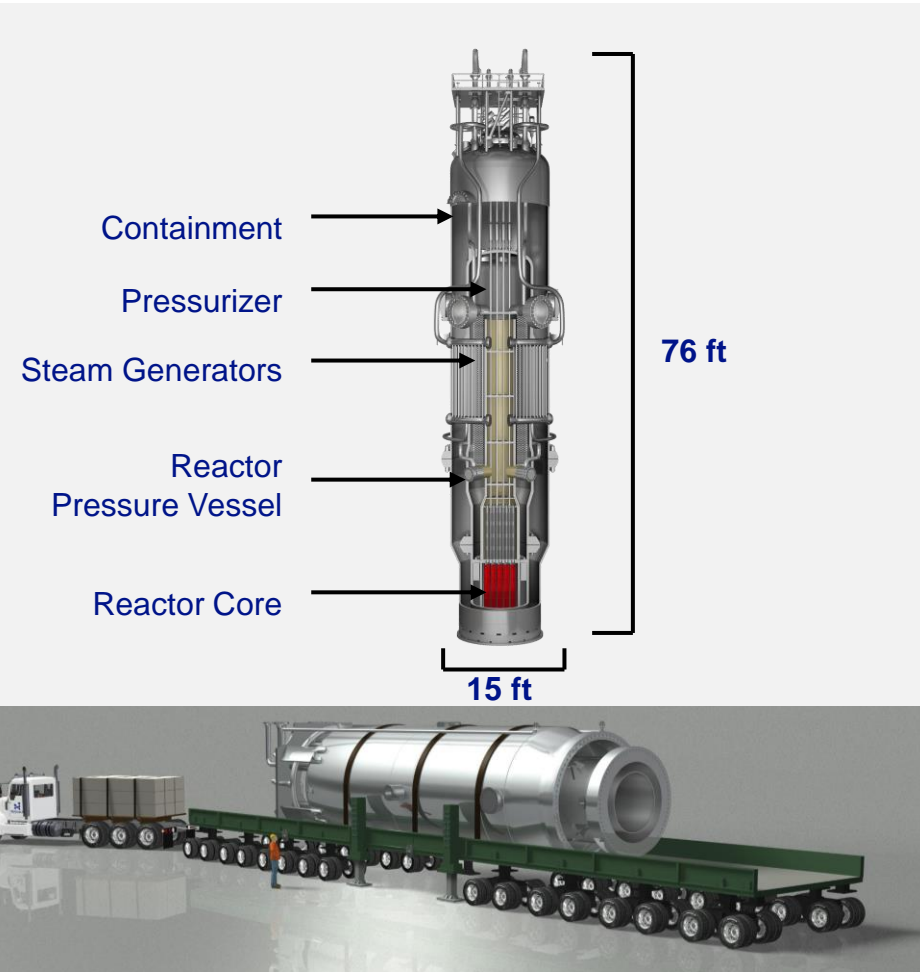

- Groundbreaking technology features a **fully factory fabricated** SMR referred to as a NuScale Power Module™ consisting of an **integral nuclear steam supply system** in which the reactor core, steam generators and pressurizer are all contained in a single vessel
- **Simple design** eliminates reactor coolant pumps, large bore piping and other systems and components found in conventional reactors
- Simplicity results in an extremely **strong safety case** and **reduced capital and operational costs**
- Modules can be incrementally added to match load growth

NuScale Power Module™ Specifications

Electrical Capacity	77 MWe
Modules per Plant	Up to 12 (924 MWe)
Design Life	60 years
Fuel Supply	Existing light water reactor nuclear fuel
Safety	Walk-away safe
Emergency Planning Zone (EPZ)	Supports site boundary EPZ

Source: NuScale WPC 2025 Presentation

Electrification of crackers is still under development

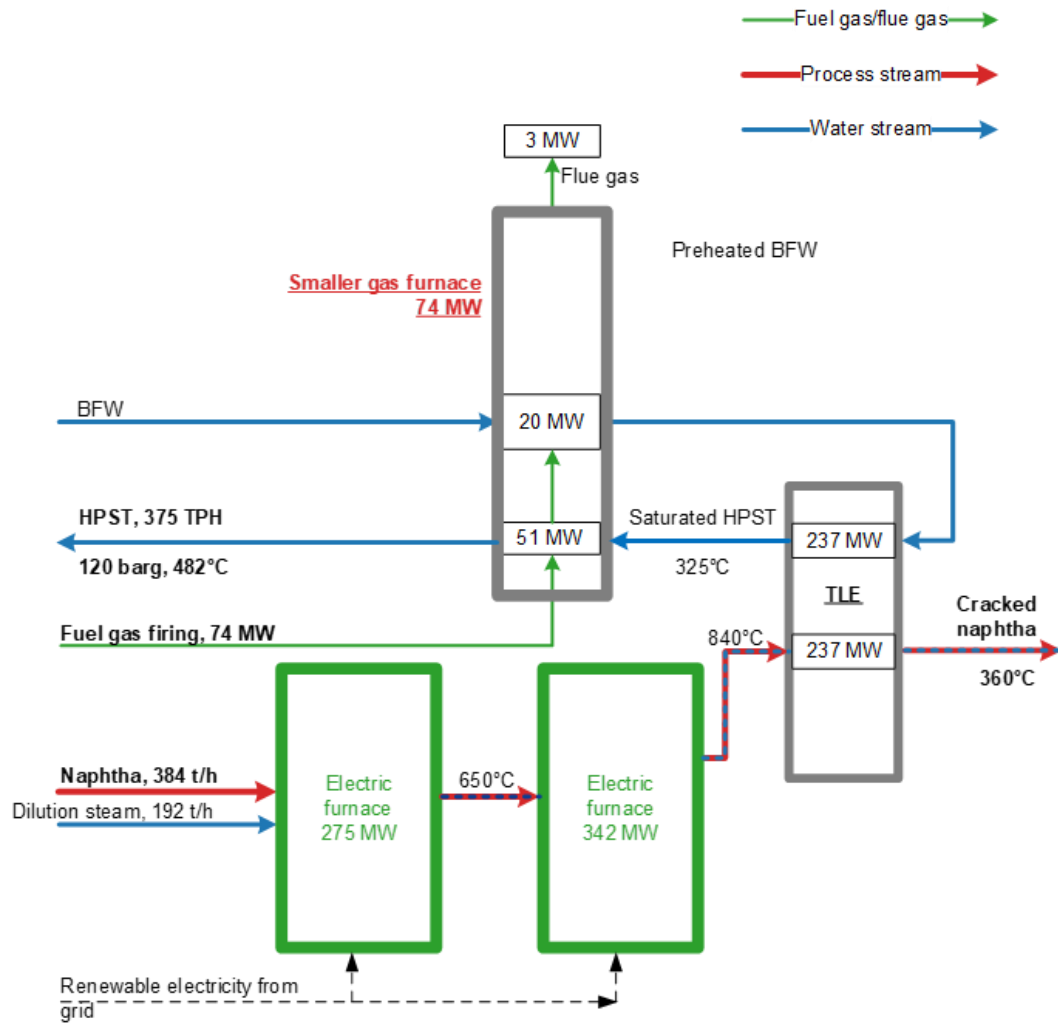

BFW = Boiler feed water; HPST = High-pressure steam; MMt/y = Million metric tons per year; MW = Megawatt; t/h = Metric tons per hour; TLE = Transfer line exchanger.
 Source: S&P Global Markit Process Economics Program (PEP) Report 290 Ethylene e-Cracker: Comparative Analysis of Electricity Sources

Linde/ BASF/ SABIC consortium at BASF Germany with separate direct and indirect heating concepts

Shell/Dow, Netherlands, experimental unit going into pilot plant

Technip, LyondellBasell and Chevron Phillips Chemical MOU to design, construct, and operate demonstration unit using Technip technology to produce olefins in Texas

Coolbrook/ ABB/ Linde: MOU to commercialize Coolbrook's Roto Dynamic Reactor technology currently in pilot scale in Netherlands

Technology developments are driven largely by decarbonization targets. There are multiple opportunities to manage emissions along the value chain

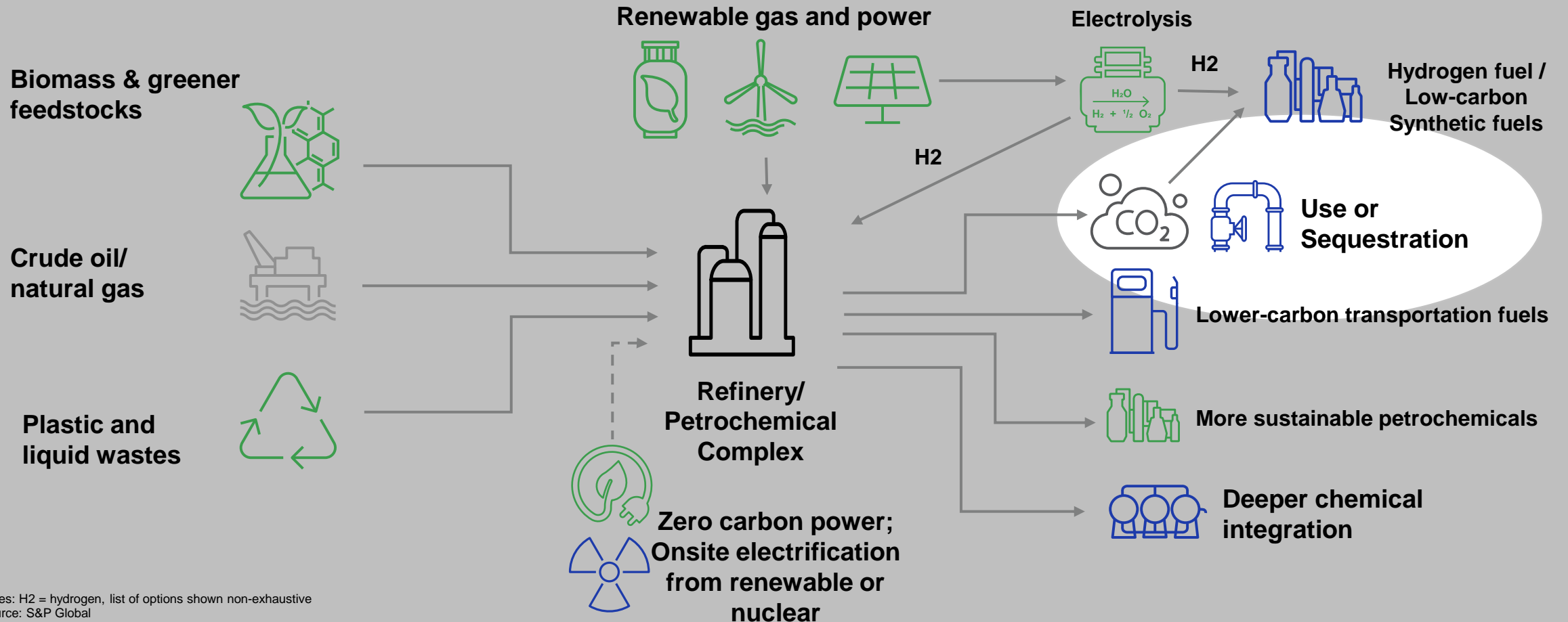

Notes: H₂ = hydrogen, list of options shown non-exhaustive
Source: S&P Global

Carbon capture solution from big to small concentrations are available and in development

Solvent absorption

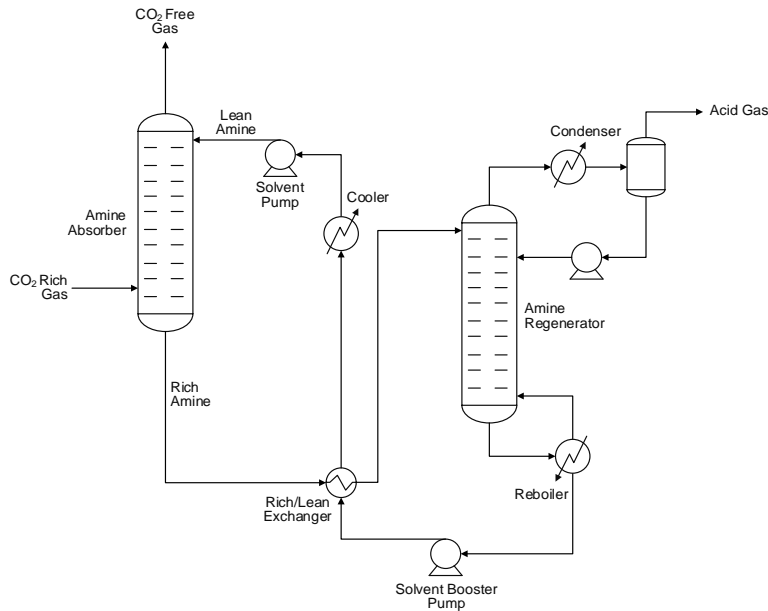

Rapid temperature swing absorption

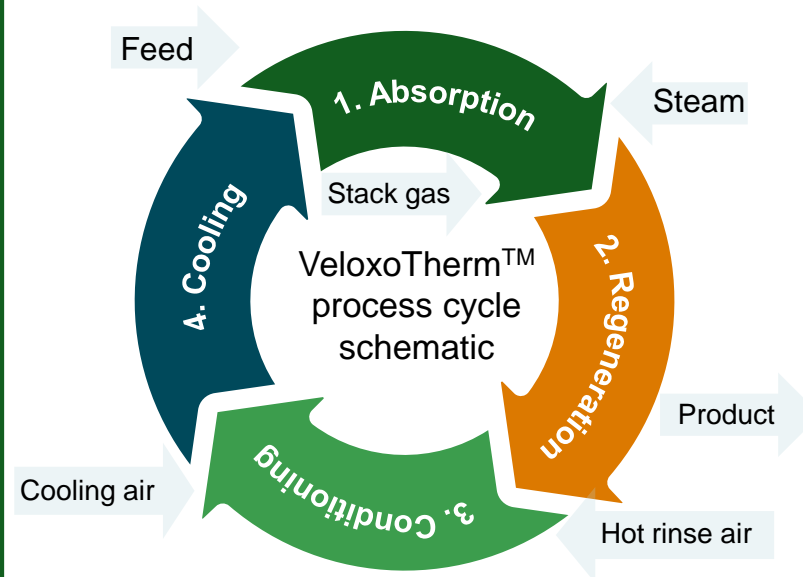

Direct CO₂ capture with caustic absorber

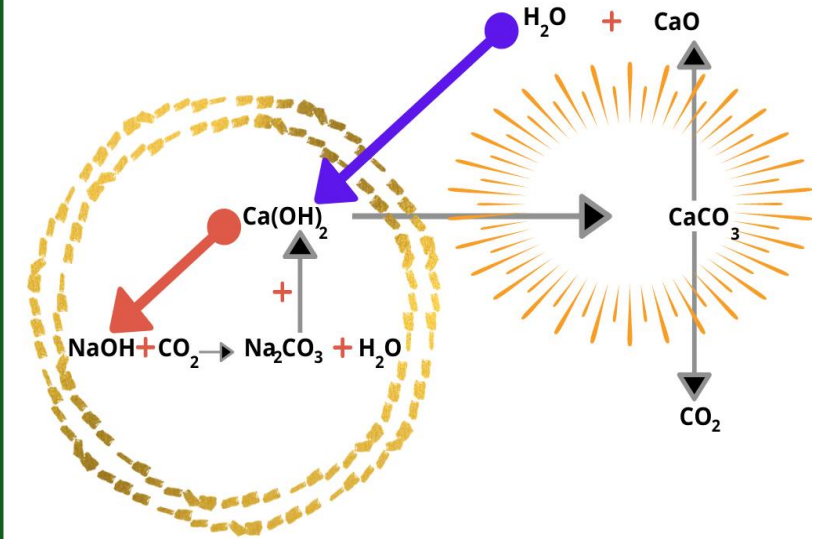

Source: S&P Global Markit Process Economics Program (PEP) Report 180F Next Generation Carbon Capture

Carbon capture economics (US, 2024) show decreasing CO₂ concentrations lead to increasing cost

Carbon capture costs

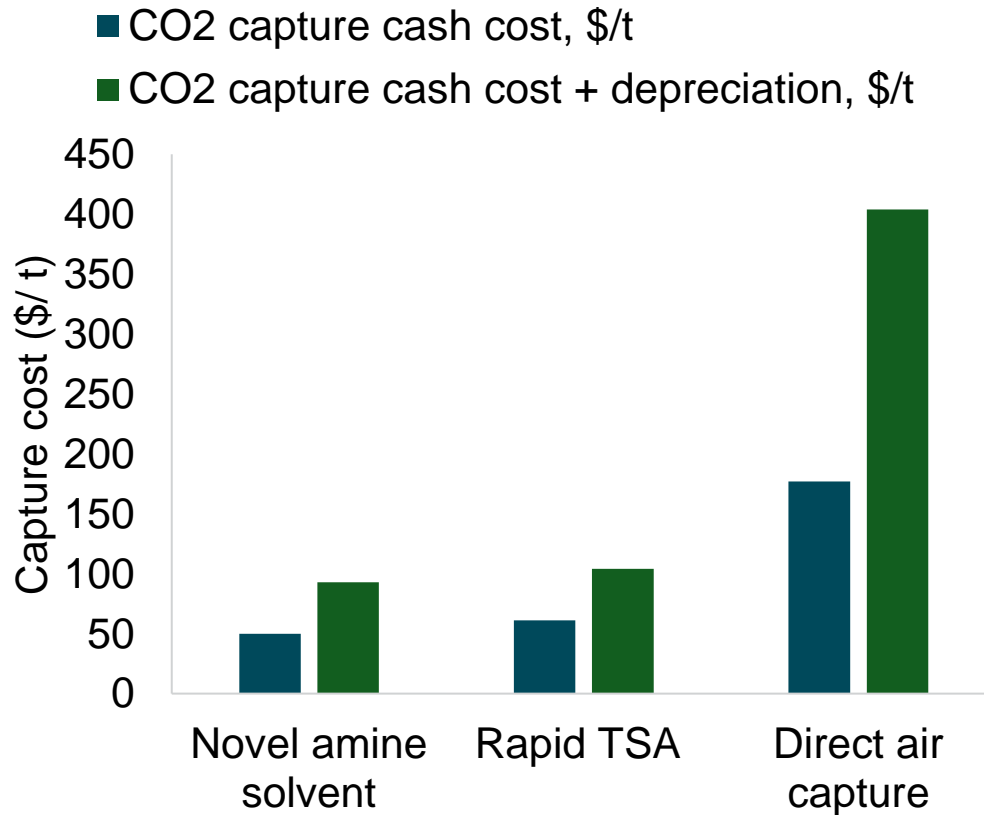

Capital cost intensity, \$/t (CO₂ captured/y)

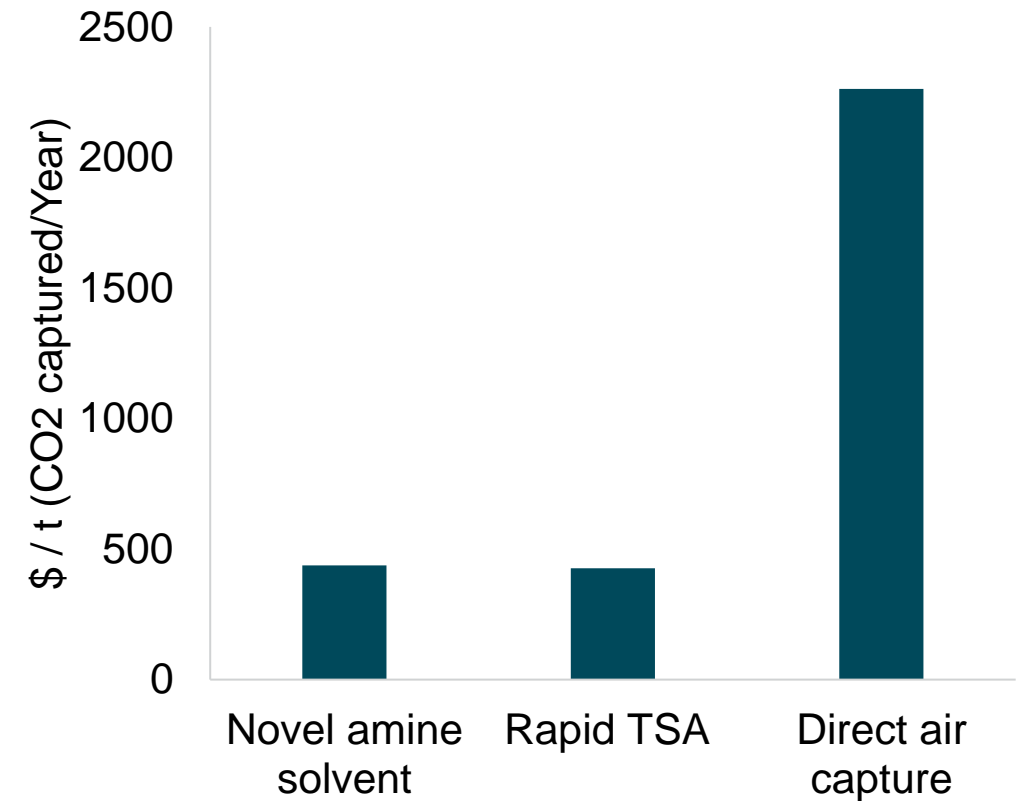

Source: S&P Global Markit Process Economics Program (PEP) Report 180F Next Generation Carbon Capture

Technology developments are driven largely by decarbonization targets. There are multiple opportunities to manage emissions along the value chain

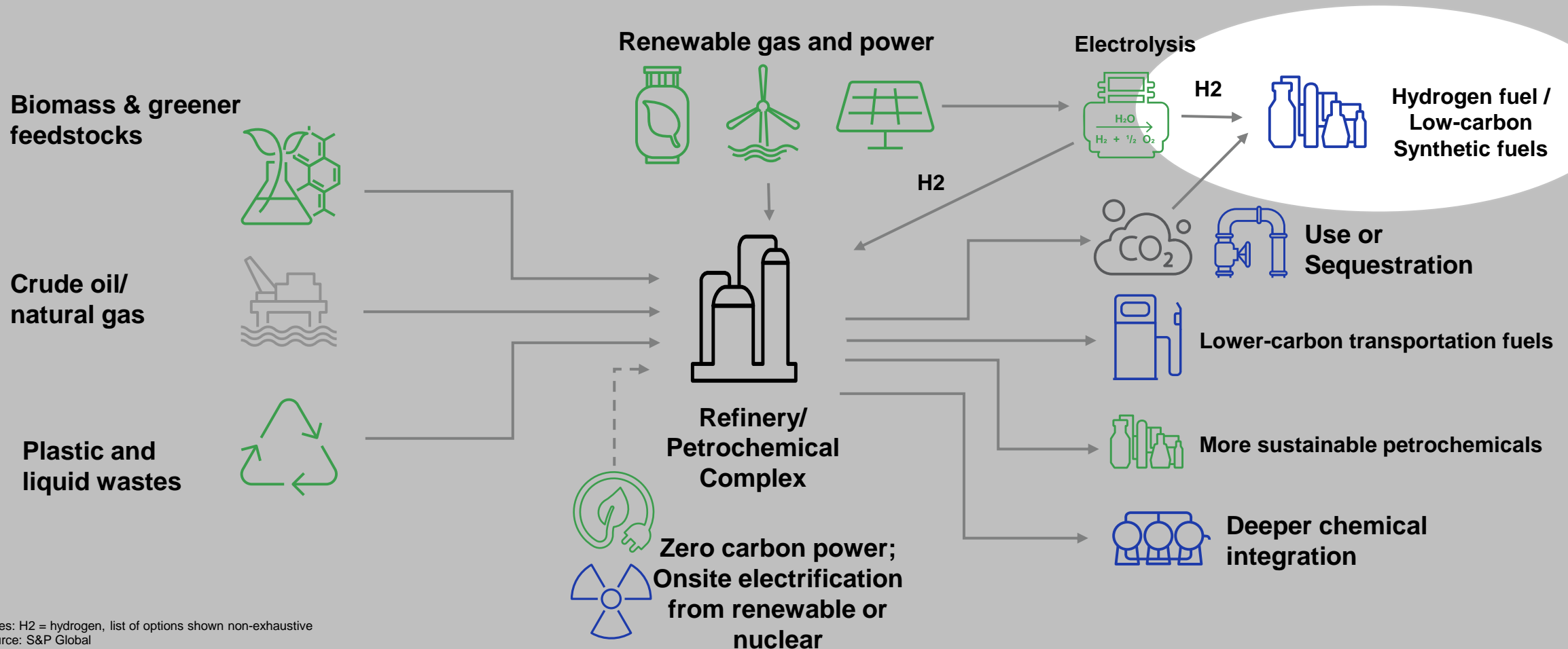

Notes: H₂ = hydrogen, list of options shown non-exhaustive
Source: S&P Global

Retrofitting cracker furnaces for hydrogen as fuel is feasible but expensive, even with low-cost hydrogen

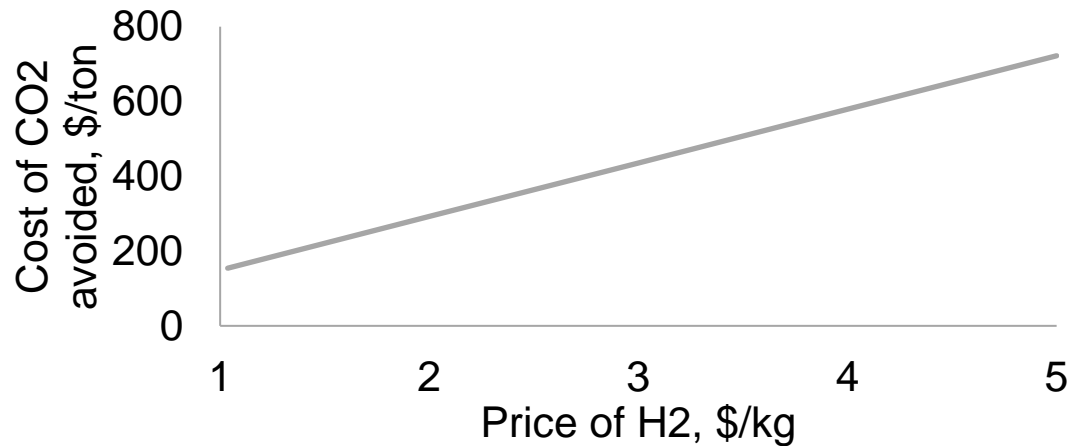
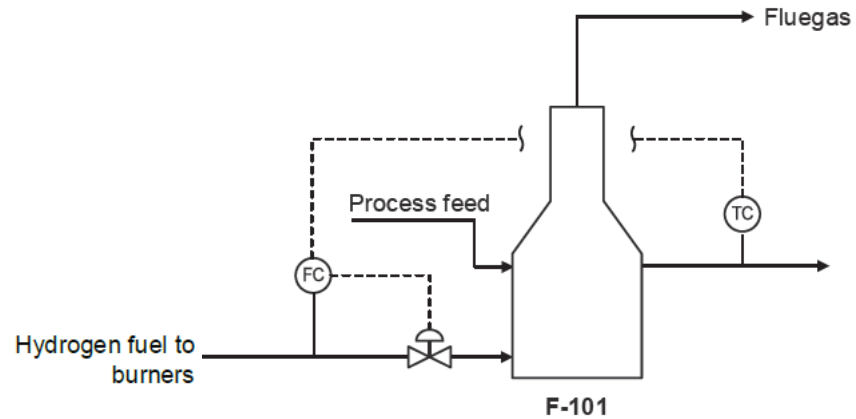

Source: S&P Global Markit Process Economics Program (PEP) Report 32H Retrofitting for Hydrogen as a Fuel

Optimal performance requires case-by-case evaluation of factors

- Flame length
- Flame speed

Hydrogen as fuel impacts radiation heat transfer

- No soot reduces radiation produced by solid particles
- Higher emissivity of H₂O in hydrogen combustion increases flue gas radiation

Increased NO_x emissions from higher flame temperatures require mitigation by burner replacement with low-NO_x burners

Dow is aiming for net zero for its new project in Fort Saskatchewan, Alberta, Canada

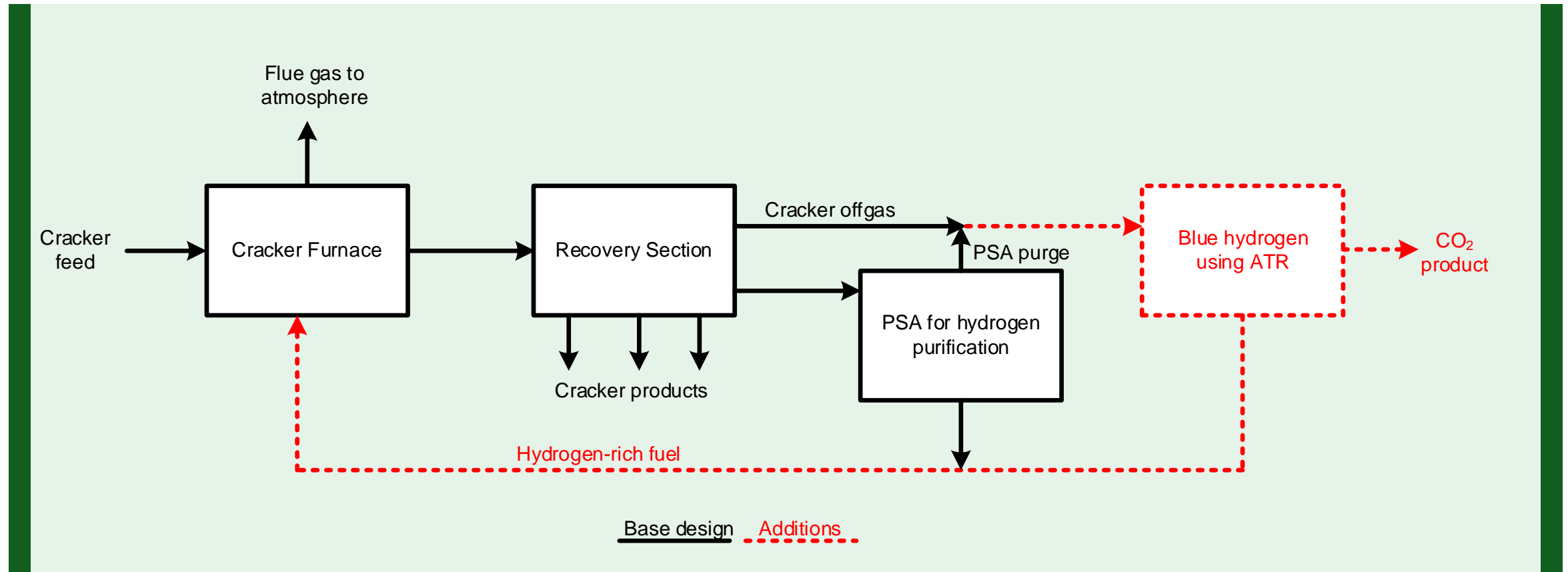

PSA: Pressure Swing Adsorption, ATR: Auto thermal reforming
Source: Process Economics Program (PEP) Review 2022-05: Dow Net-Zero Olefins from Ethane

Alternative is a CO₂ separation section as an independent unit added to an existing facility

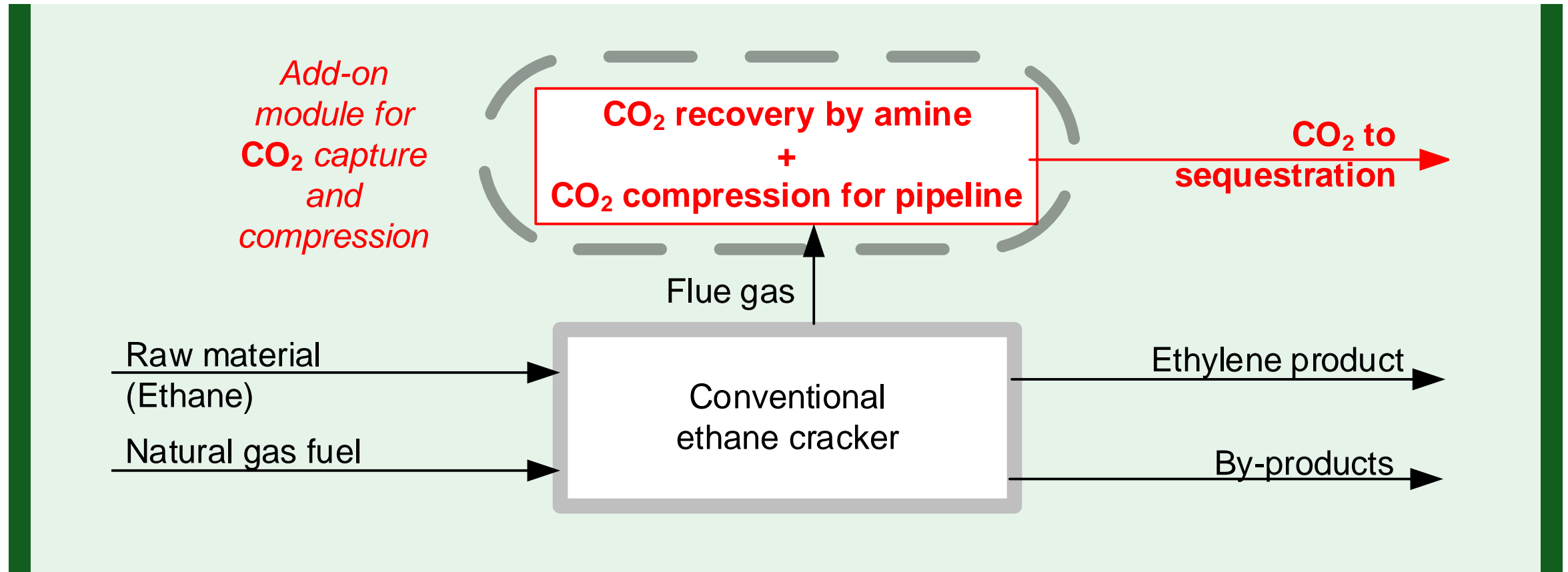

Source: Process Economics Program (PEP) Review 2022-05: Dow Net-Zero Olefins from Ethane

Dow Net-Zero avoids and emits substantially less carbon than conventional ethane cracking

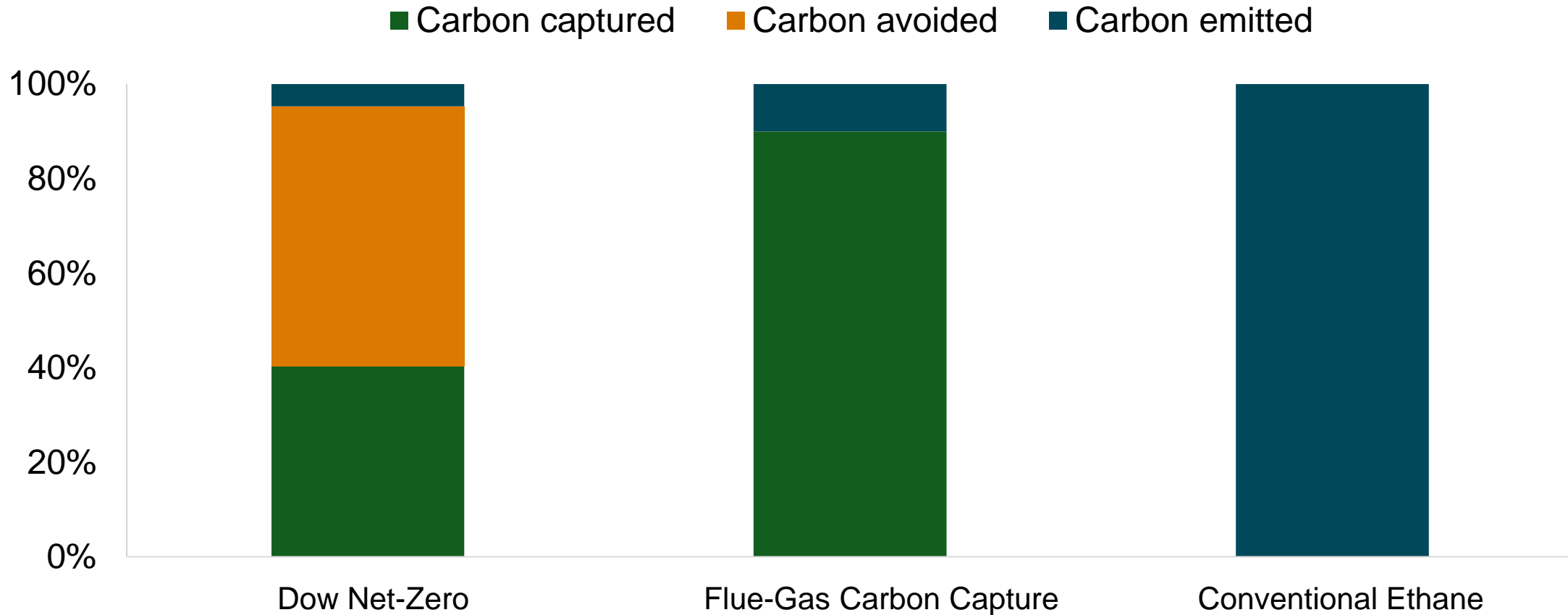

Source: Process Economics Program (PEP) Review 2022-05: Dow Net-Zero Olefins from Ethane

Reduction comes at higher CAPEX and OPEX than standard ethane cracking

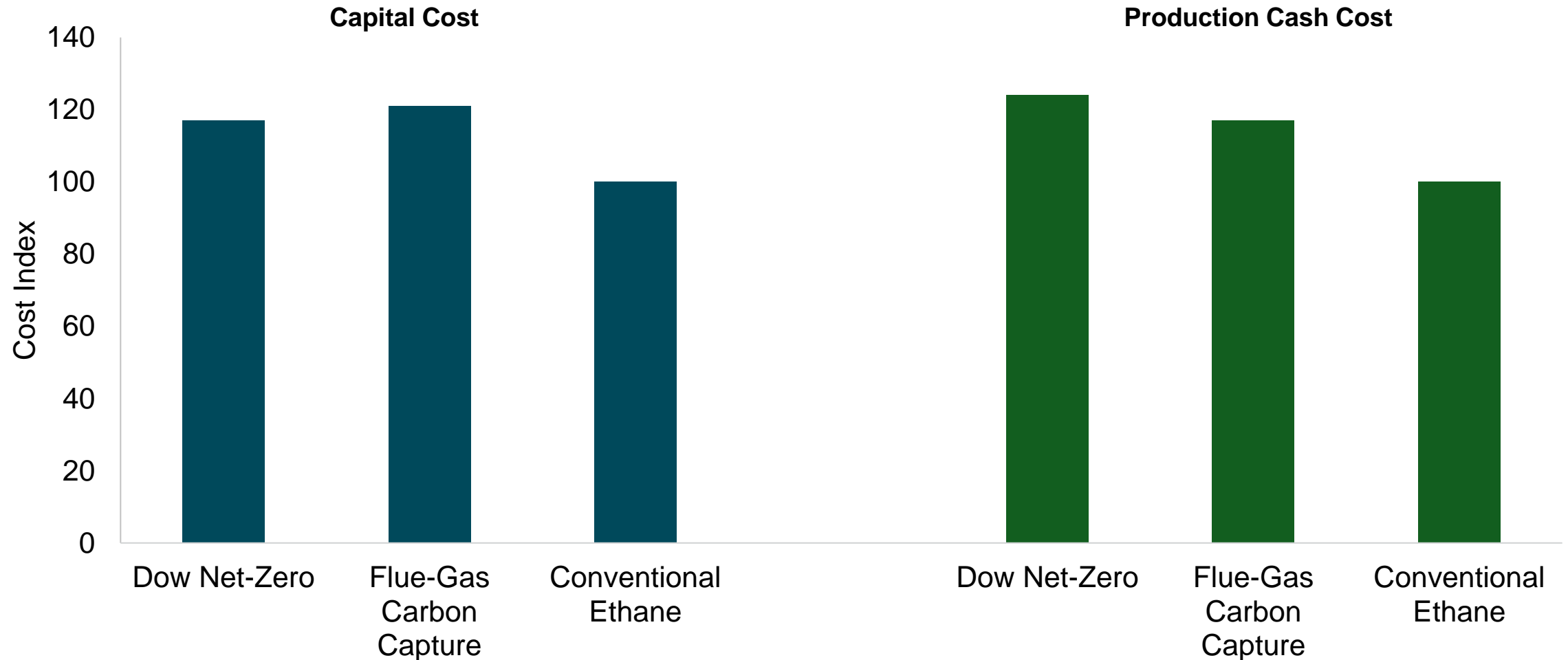

Source: Process Economics Program (PEP) Review 2022-05: Dow Net-Zero Olefins from Ethane

Technology developments are driven largely by decarbonization targets. There are multiple opportunities to manage emissions along the value chain

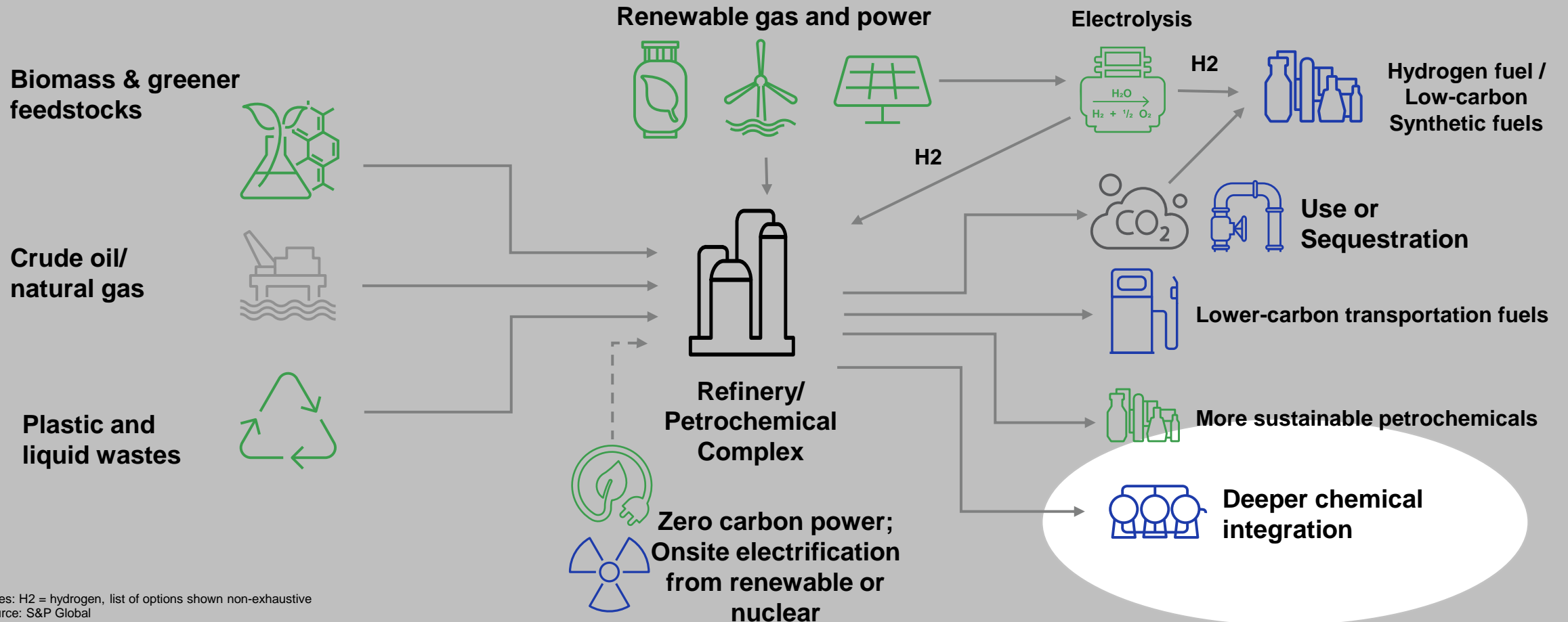

Notes: H₂ = hydrogen, list of options shown non-exhaustive
Source: S&P Global

Saudi Aramco's approach to COTC is olefins focused using Thermal Crude to Chemical (TC2C) technology located at S-Oil's Shaheen complex in South Korea

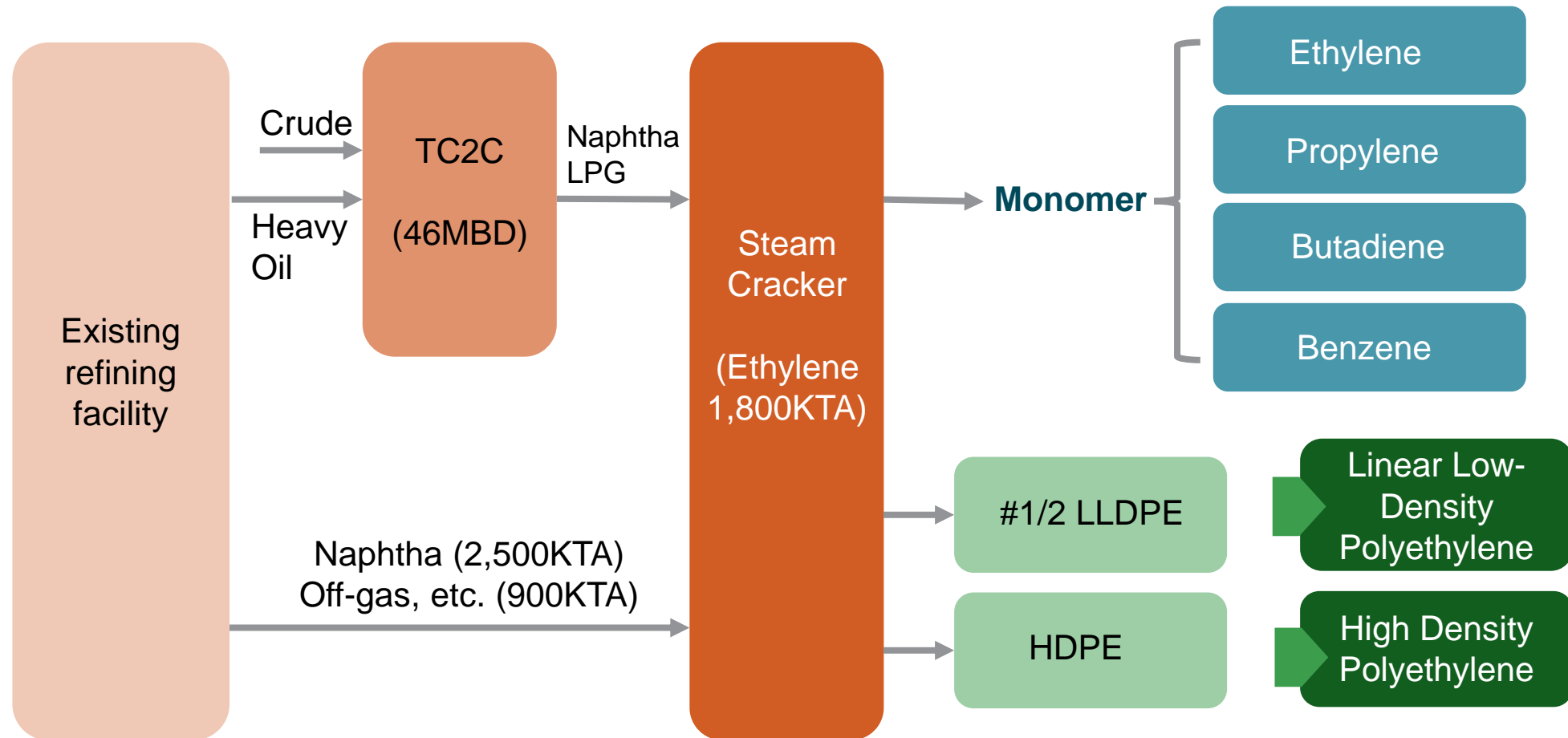

Source: Shaheen Project Investor Briefing

Thermal Crude to Chemical (TC2T) technology involves several unit operations

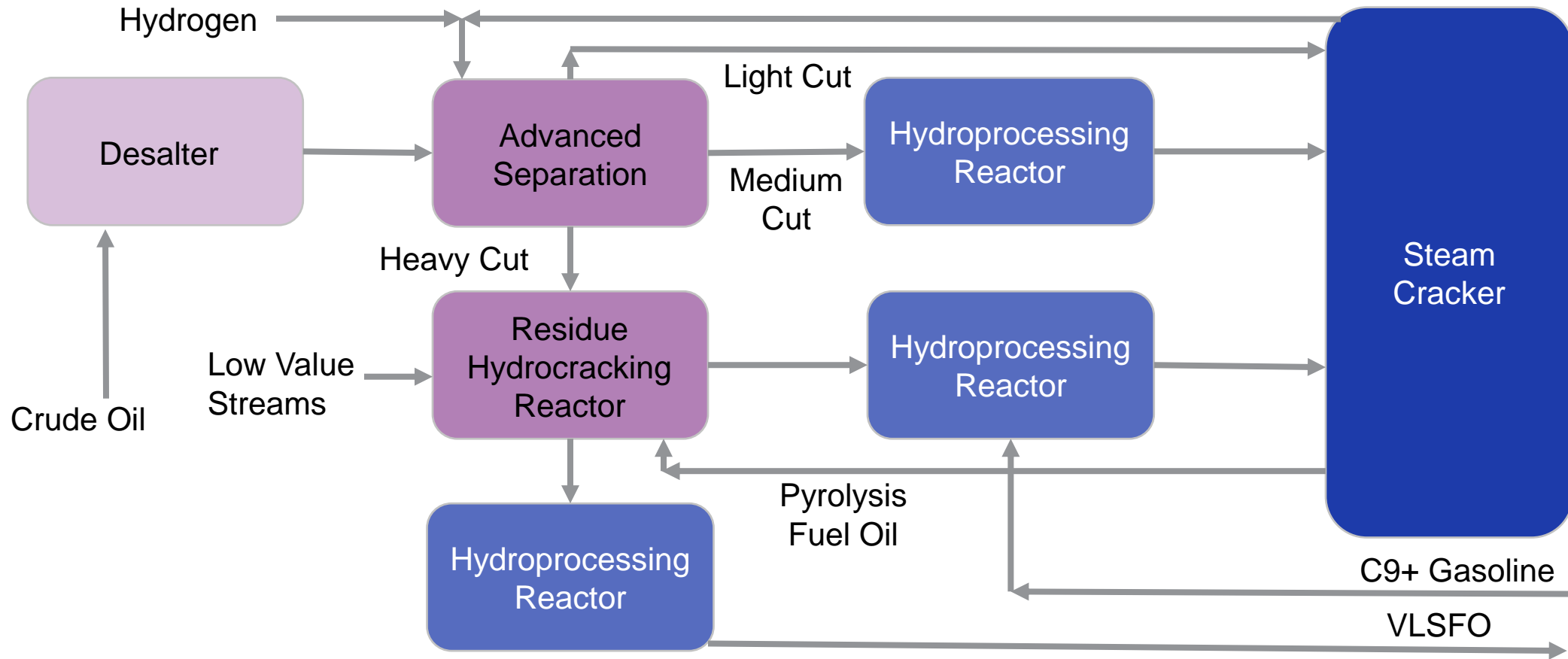

Source: Aramco MEPEC 2024 Presentation, TC2C™ More Carbon Effective Conversion of Crude into Chemicals

Despite its scale, COTC for olefins is at best mid-quartile on the cost curve at market price oil

Saudi gas initiatives will increase ethane/NGL availability for petchems

Nevertheless, Saudi Aramco plans to convert up to 4 million b/d of crude oil to chemicals, both in Kingdom and in destination markets

COTC is CAPEX intensive and cash cost is similar to naphtha cracking at a market price for oil

TC2C™ cash cost of production (US\$/Ton)

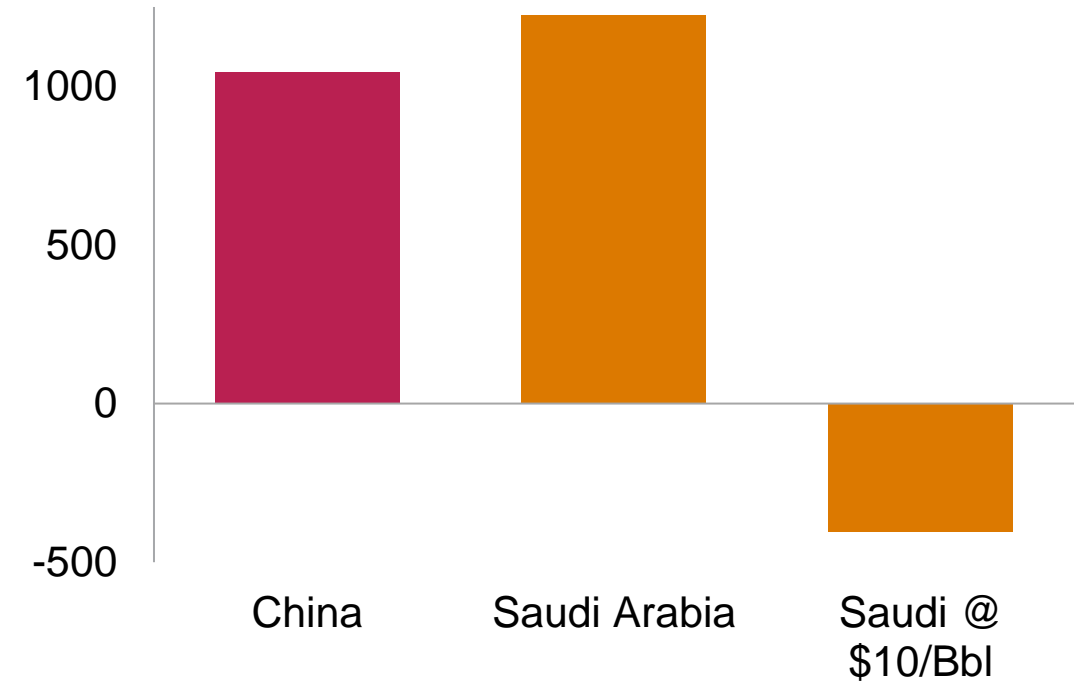

*Based on Q3 2024 prices
Data compiled 8 Jan 2025
Source: S&P Global Commodity Insights, Process Economics Program (PEP)

Honeywell have developed naphtha to ethane & propane (NEP) as a step-change in olefins production efficiency and bankable investments

+ 3.7% IRR & +\$1.1 Billion NPV10
 ~ 79% conversion of crude to chemicals
 > 35% Net Cash Margin per bbl of crude
 > 25% improved capital efficiency/ton

40% reduced CO2/ton of light olefin
 40% crude reduction for same LO
 Eliminate fuels export; minimize scope 3

Wide range of E/P design flexibility
 Zero net propane / propylene option
 MOU signed with Petro Rabigh

Source: Honeywell WPC 2025 Presentation
 Economic results shown for 2,260 KMTA Light olefins investment relative to base

NEP-Based Light Olefins Complex

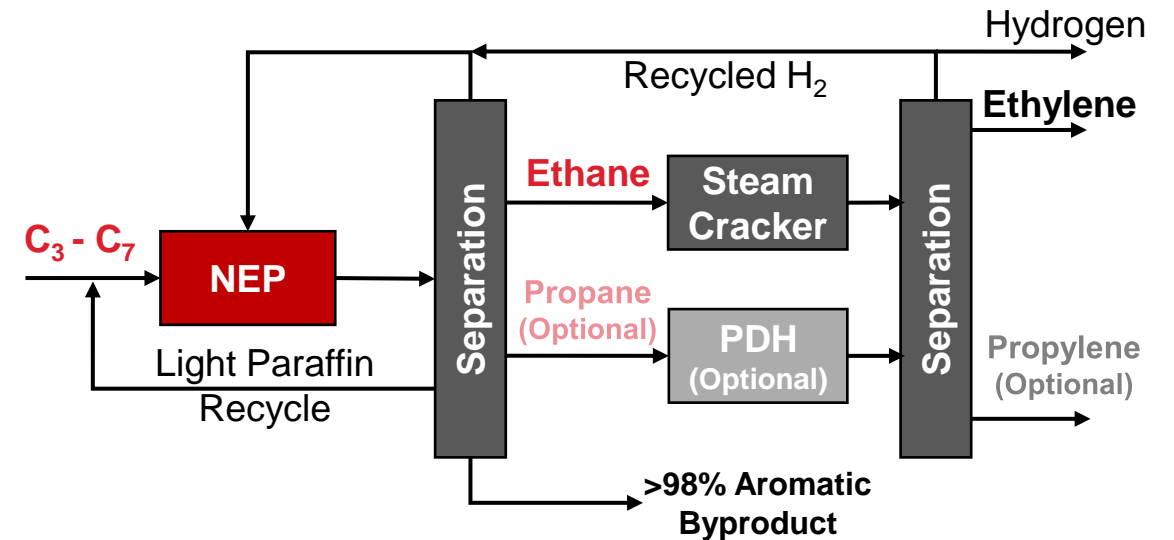

Agenda

A future certainty

A smorgasbord of options

The devil is in the detail

Another future certainty

Key takeaways



Within a petrochemical complex, emissions from other plants of typical capacity are dwarfed by those from a cracker

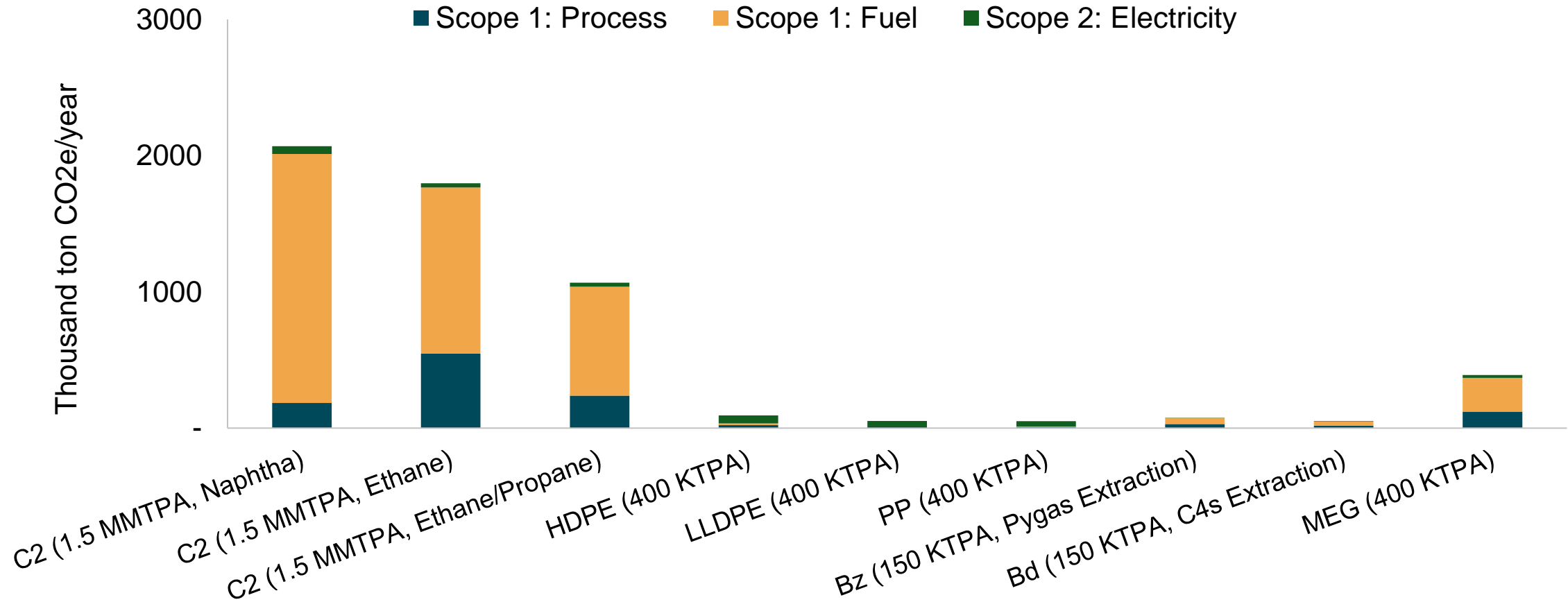

Source: S&P Global Refinery & Petrochemical Integrator & Decarbonizer (RAPID)

Another certainty: Decarbonizing the industry will cost a lot! But how much?

Case Study: Existing cracker and derivatives complex in SE Asia

1 million tons/year ethylene from naphtha

Corresponding LLDPE, HDPE, PP, Benzene & Butadiene production

Scope 1 and Scope 2 emissions abatement from 2028

Carbon capture and sequestration

Zero-emissions electricity production

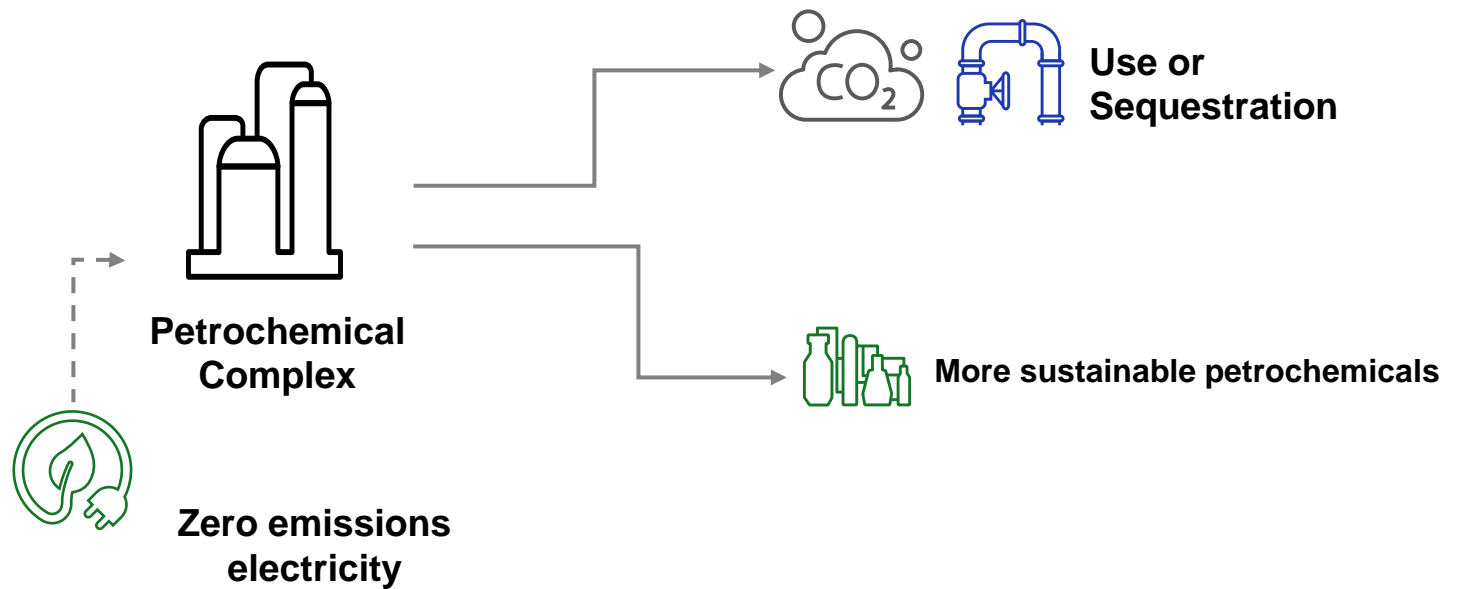

Source: S&P Global Refinery & Petrochemical Integrator & Decarbonizer (RAPID)

Substantial product premiums and/or carbon credits will be needed to maintain future financial performance

Substantial CAPEX and increased OPEX



CAPEX of well over \$1 billion to achieve 70% carbon emissions reduction



25-year EBIT reduced by over \$5 billion



EBIT parity:
~150 \$/ton “low-carbon” polymer product premium or
~130 \$/ton of CO2 credit for emissions avoided

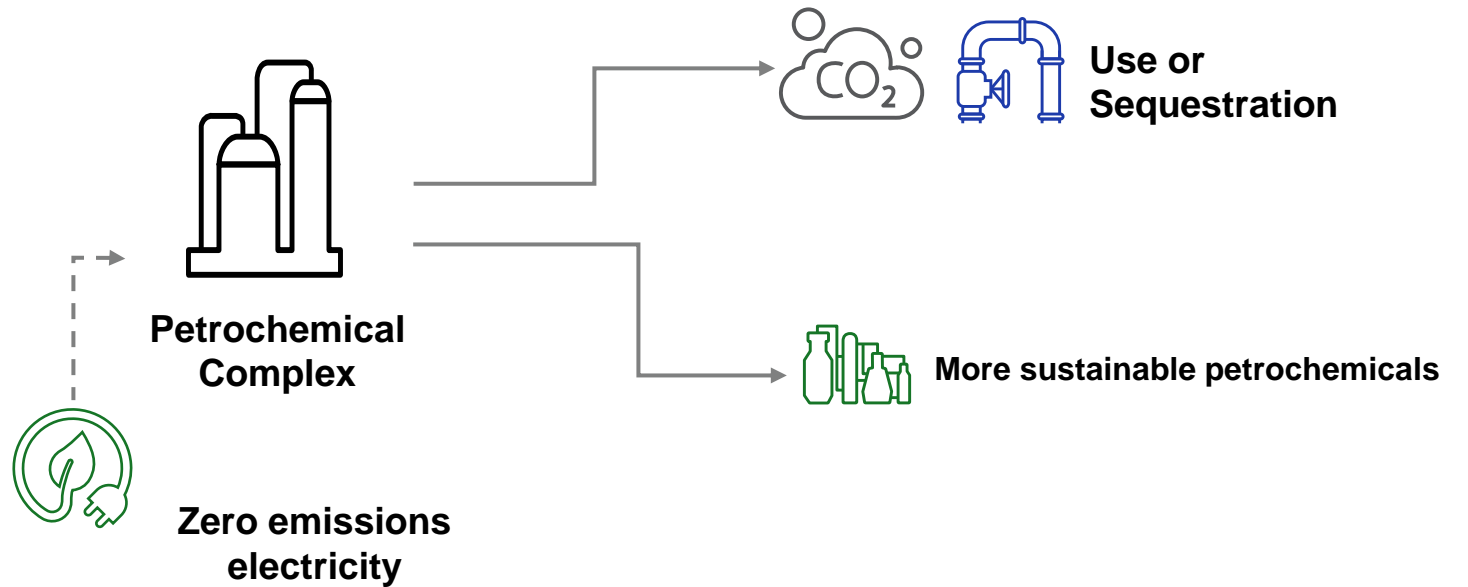

Source: S&P Global Refinery & Petrochemical Integrator & Decarbonizer (RAPID)

Agenda

A future certainty

A smorgasbord of options

The devil is in the detail

Another future certainty

Key takeaways



Key Takeaway: Setting up a petrochemical industry for the future will require huge investment for decarbonization and mechanisms to offset the costs

The future petrochemical industry will be a decarbonized one albeit the pace is slowing

Multiple decarbonization technology options available but vary in commercialization

Substantial CAPEX and OPEX is required to achieve decarbonization targets

Government policy-driven carbon credits and/or green-product premiums will be needed to offset the EBIT decline

